

MODEL T2A-B

120 X 200 CM



FIBERGLASS ENCLOSURE

- Overall L x W x H : 2105x1300x1430mm
- Enclosure : Composite Honeycomb Sandwich Panels
- Base : Concrete covered with Polyester
- Removable Hinged Doors (External Safety Lock on two Doors)
- Removable Roof and Corners
- Four Lifting Eye Bolts
- Openings through the Base and Central Gutter for Electric Cables
- Large Groutable Opening in the Base for Pipes and Plumbing Accessories
- Ground Anchoring Provisions in the Base, for M20 Anchor Stems
- Forced Air Ventilation System
- External Gelcoat, Grey Colour RAL 7047
- Total Weight : approx. 1500 kg
- Options :
 - Soundproof Insulation
 - Brick or Stone Facings on the Doors and Corners

CUTAWAY

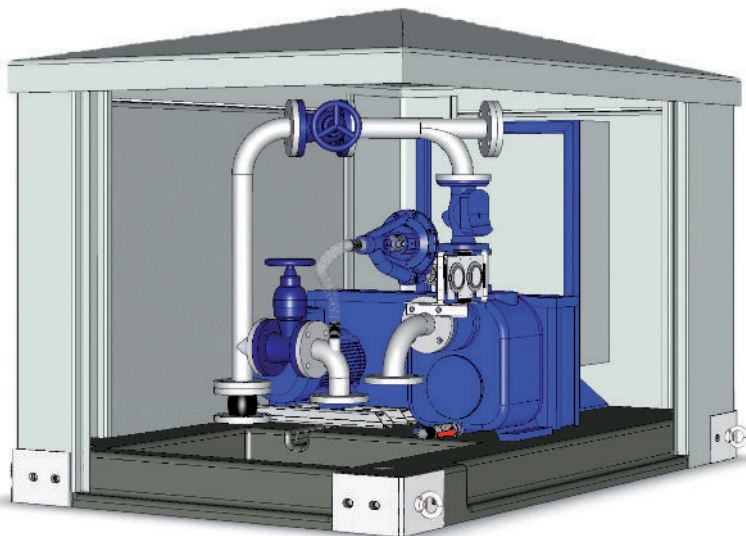

SELF PRIMING PUMP T2A-B

ES



Quantity: 1

Size: 2"x2" DN50 DIN Flanges

Maximum Capacity: 50 m³/h

Maximum Head: 32 m

Maximum Self Priming Lift: -7,3 m

Maximum Solids: 38 mm

Model available in Different Materials: T2A3-B /FM, T2A60-B /FM, T2A61-B /FM, T2A71-B /FM and T2A65-B /FM. Refer to The Gorman-Rupp Specification sheet for details on the available pumps.

GRE
MAY 2012

DRIVING SYSTEM

V-belt Transmission: 1 x IEC Electrical Motor, IP55, 50 Hz, Efficiency Class IE2

Safety Transmission Guard

PUMP EQUIPMENT

- 1 x Air Release Valve Gorman-Rupp GRP 33-07 with Isolation Ball Valve and Transparent Hose
- 1 x Pump Casing High Temperature Shutdown Kit
- 1 x Suction and Discharge Pressure Gauge, mounted on a Non-Vibrating Support
- 1 x Pump Casing Drainage System, with Isolation Ball Valve and Transparent Hose

PIPINGS AND PIPING ACCESSORIES

> All Flanges are DIN PN10

- 1 x Suction Pipe in Stainless Steel 304, DN50 Flanged
- 1 x Common Discharge Pipe in Stainless Steel 304 ended by an Expansion Joint, DN50 Flanged
- 1 x Non-Return Valve, DN50 Flanged
- 1 x Eccentric Plug Valve, DN50 Flanged
- 1 x Access Cover on the Discharge Pipe, DN50 Flanged
- 1 x By-Pass Pipe in Stainless Steel 304 on the Discharge Pipe with Eccentric Plug Valve, DN50 Flanged

OTHER INTERNAL EQUIPMENT

- 1 x Electrical Heating Element 750W / 1x230V with Adjustable Thermostat
- 1 x Extraction Fan (325m³/h)
- 1 x Electrical Plug CEE 2P+T 230V 16A
- 1 x Internal Lighting

ELECTRICAL BOX WITH AUTOMATIC LEVEL CONTROL (AVAILABLE AS AN OPTION)

GORMAN-RUPP EUROPE

Fahrenheitweg 35 - 8912 AK LEEUWARDEN, NL
Gutenbergweg 6 - 4104 BA CULEMBORG, NL
T. +31 582 12 37 74 - gresales@gormanruppeurope.com



MODEL T2A-B

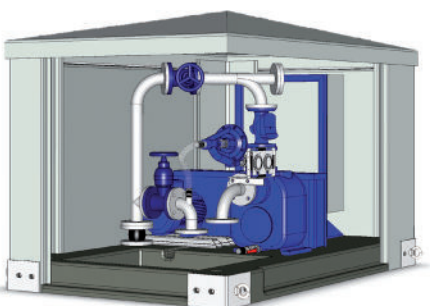
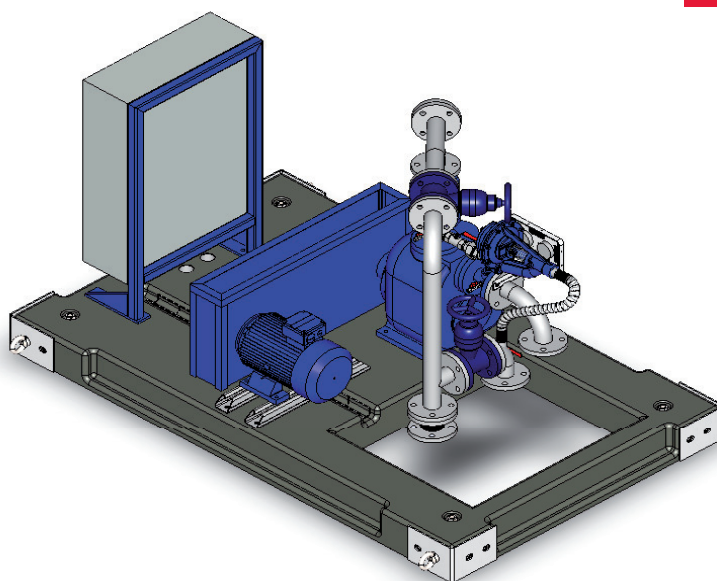
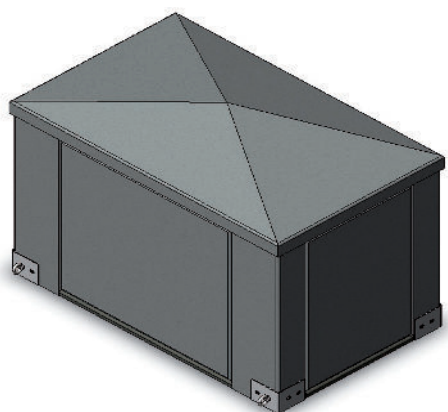

GORMAN-RUPP EUROPE

Fahrenheitweg 35 - 8912 AK LEEUWARDEN, NL
Gutenbergweg 6 - 4104 BA CULEMBORG, NL
T. +31 582 12 37 74 - gresales@gormanruppeurope.com



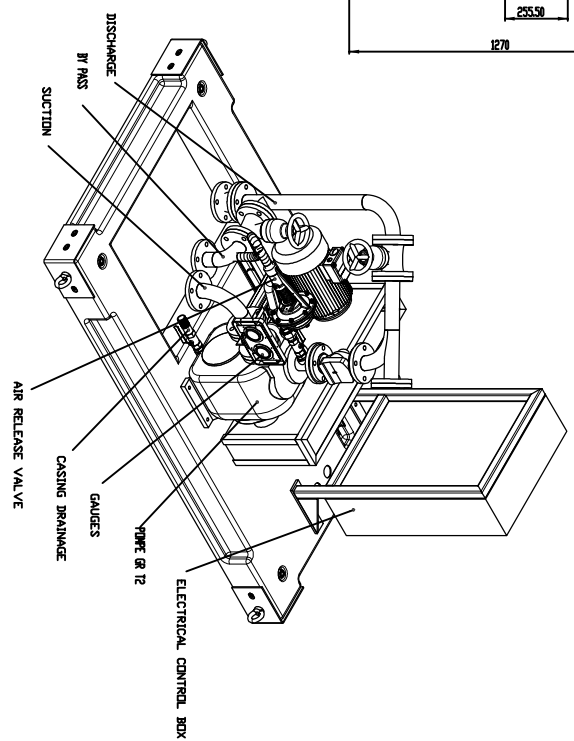
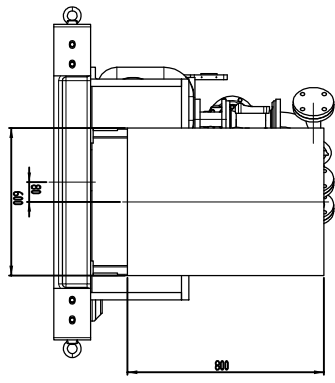
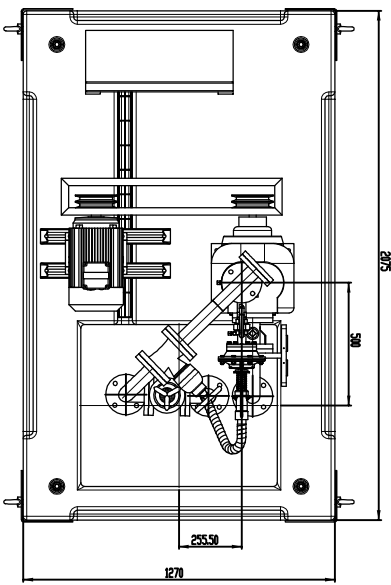
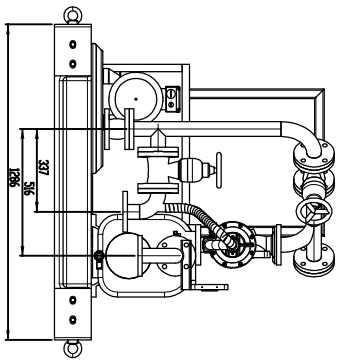
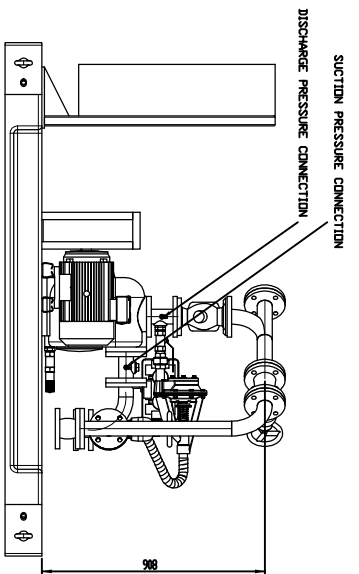
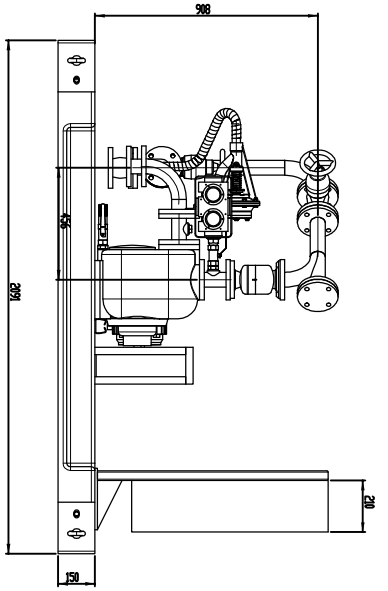



GORMAN-RUPP EUROPE
 GORMAN-RUPP
 8500 Wieringerland 25A
 The Netherlands 74
 Tel. +31 586 12 57 74
 Fax. +31 586 12 50 57

Above Ground Lift Station
 Type 120x200
 1 x Pump Gorman-Rupp T2A-B/FM

MODEL T3A-B

120 X 200 CM



FIBERGLASS ENCLOSURE

- Overall L x W x H : 2105x1300x1430mm
- Enclosure : Composite Honeycomb Sandwich Panels
- Base : Concrete covered with Polyester
- Removable Hinged Doors (External Safety Lock on two Doors)
- Removable Roof and Corners
- Four Lifting Eye Bolts
- Openings through the Base and Central Gutter for Electric Cables
- Large Groutable Opening in the Base for Pipes and Plumbing Accessories
- Ground Anchoring Provisions in the Base, for M20 Anchor Stems
- Forced Air Ventilation System
- External Gelcoat, Grey Colour RAL 7047
- Total Weight : approx. 1600 kg
- Options :
 - Soundproof Insulation
 - Brick or Stone Facings on the Doors and Corners

CUTAWAY

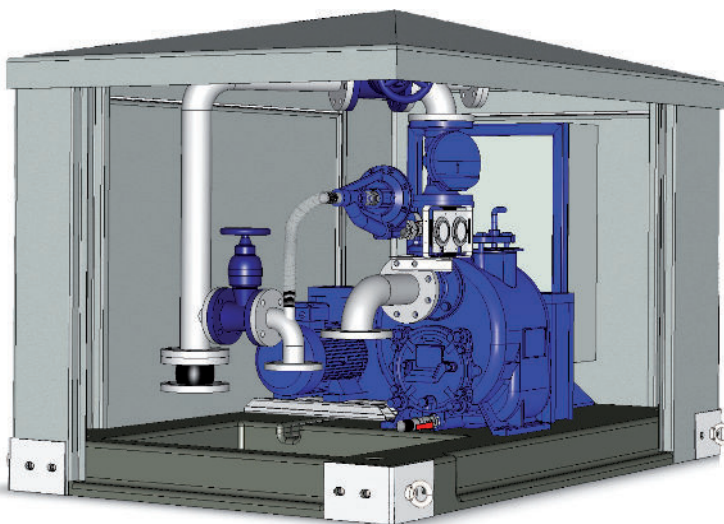

SELF PRIMING PUMP T3A-B

ES



Quantity: 1

Size: 3"x3" DN80 DIN Flanges

Maximum Capacity: 100 m³/h

Maximum Head: 34 mWC

Maximum Self Priming Lift: -7,6 m

Maximum Solids: 63 mm

Model available in Different Materials: T3A3S-B /FM, T3A60S-B /FM, T3A61S-B /FM, T3A71S-B /FM and T3A65S-B /FM. Refer to The Gorman-Rupp Specification sheet for details on the available pumps

GRE
MAY 2012

DRIVING SYSTEM

V-belt Transmission: 1 x IEC Electrical Motor, IP55, 50 Hz, Efficiency Class IE2

Safety Transmission Guard

PUMP EQUIPMENT

- 1 x Air Release Valve Gorman-Rupp GRP 33-07 with Isolation Ball Valve and Transparent Hose
- 1 x Pump Casing High Temperature Shutdown Kit
- 1 x Suction and Discharge Pressure Gauge, mounted on a Non-Vibrating Support
- 1 x Pump Casing Drainage System, with Isolation Ball Valve and Transparent Hose

PIPINGS AND PIPING ACCESSORIES

> All Flanges are DIN PN10

- 1 x Suction Pipe in Stainless Steel 304, DN80 Flanged
- 1 x Common Discharge Pipe in Stainless Steel 304 ended by an Expansion Joint, DN80 Flanged
- 1 x Non-Return Valve, DN80 Flanged
- 1 x Eccentric Plug Valve, DN80 Flanged
- 1 x Access Cover on the Discharge Pipe, DN50 Flanged
- 1 x By-Pass Pipe in Stainless Steel 304 on the Discharge Pipe with Eccentric Plug Valve, DN50 Flanged

OTHER INTERNAL EQUIPMENT

- 1 x Electrical Heating Element 750W / 1x230V with Adjustable Thermostat
- 1 x Extraction Fan (325m³/h)
- 1 x Electrical Plug CEE 2P+T 230V 16A
- 1 x Internal Lighting

ELECTRICAL BOX WITH AUTOMATIC LEVEL CONTROL (AVAILABLE AS AN OPTION)

GORMAN-RUPP EUROPE

Fahrenheitweg 35 - 8912 AK LEEUWARDEN, NL

Gutenbergweg 6 - 4104 BA CULEMBORG, NL

T. +31 582 12 37 74 - gresales@gormanruppeurope.com



MODEL T3A-B

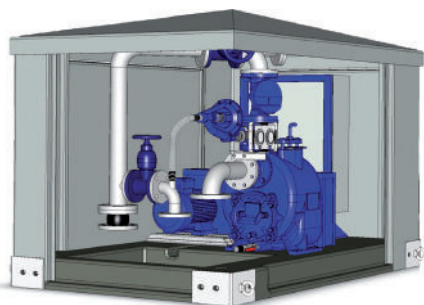
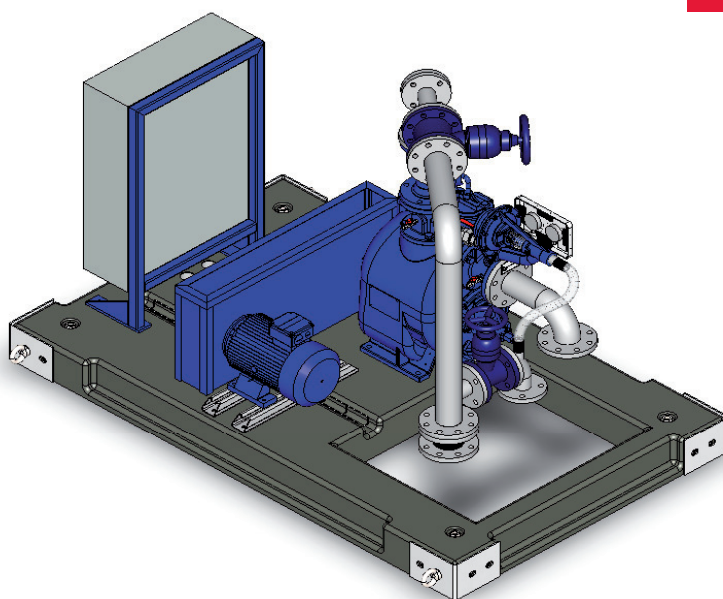
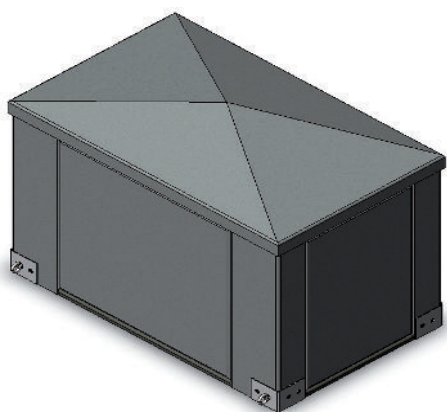

GORMAN-RUPP EUROPE

Fahrenheitweg 35 - 8912 AK LEEUWARDEN, NL
Gutenbergweg 6 - 4104 BA CULEMBORG, NL
T. +31 582 12 37 74 - gresales@gormanruppeurope.com



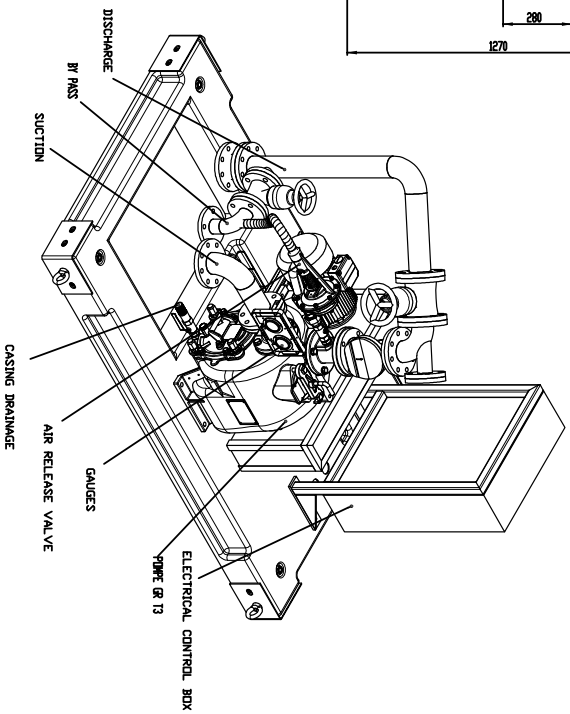
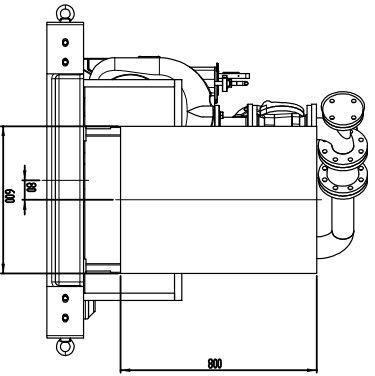
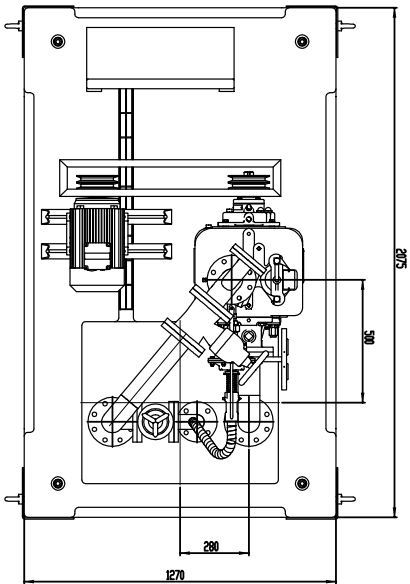
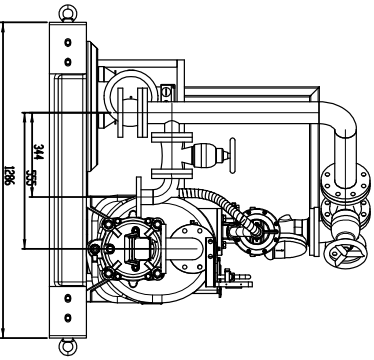
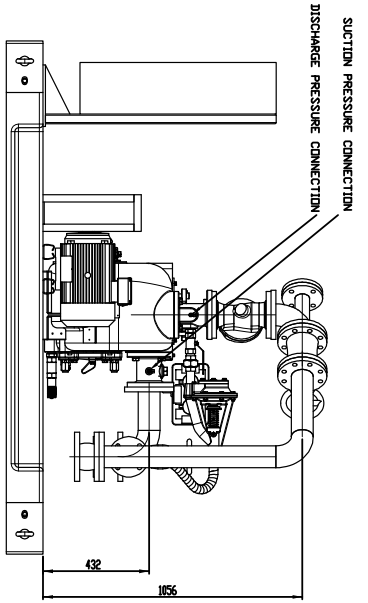
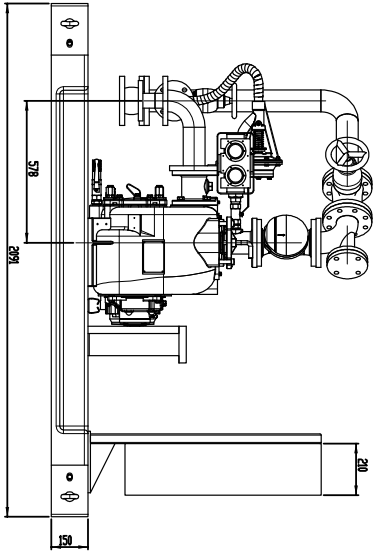



GERMAN-RUPP EUROPE

 BORNMAR-RUPP

Above Ground Lift Station
 Type 120x200
 1 x Pump Gorman-Rupp 13A-B/1M

MODEL T4A-B

120 X 200 CM



FIBERGLASS ENCLOSURE

- Overall L x W x H : 2105x1300x1430mm
- Enclosure : Composite Honeycomb Sandwich Panels
- Base : Concrete covered with Polyester
- Removable Hinged Doors (External Safety Lock on two Doors)
- Removable Roof and Corners
- Four Lifting Eye Bolts
- Openings through the Base and Central Gutter for Electric Cables
- Large Groutable Opening in the Base for Pipes and Plumbing Accessories
- Ground Anchoring Provisions in the Base, for M20 Anchor Stems
- Forced Air Ventilation System
- External Gelcoat, Grey Colour RAL 7047
- Total Weight : approx. 1800 kg
- Options :
 - Soundproof Insulation
 - Brick or Stone Facings on the Doors and Corners

CUTAWAY

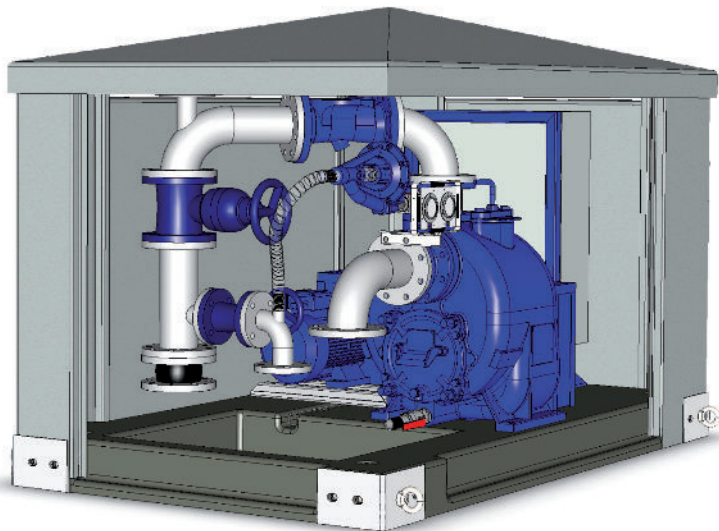

SELF PRIMING PUMP T4A-B

ES



Quantity: 1

Size: 4"x4" DN100 DIN Flanges

Maximum Capacity: 160 m³/h

Maximum Head: 34 mWC

Maximum Self Priming Lift: -7,6 m

Maximum Solids: 76 mm

Model available in Different Materials: T4A3S-B /FM, T4A60S-B /FM, T4A61S-B /FM, T4A71S-B /FM and T4A65S-B /FM. Refer to The Gorman-Rupp Specification sheet for details on the available pumps.

GRE
MAY 2012

DRIVING SYSTEM

V-belt Transmission: 1 x IEC Electrical Motor, IP55, 50 Hz, Efficiency Class IE2

Safety Transmission Guard

PUMP EQUIPMENT

- 1 x Air Release Valve Gorman-Rupp GRP 33-07 with Isolation Ball Valve and Transparent Hose
- 1 x Pump Casing High Temperature Shutdown Kit
- 1 x Suction and Discharge Pressure Gauge, mounted on a Non-Vibrating Support
- 1 x Pump Casing Drainage System, with Isolation Ball Valve and Transparent Hose

PIPINGS AND PIPING ACCESSORIES

> All Flanges are DIN PN10

- 1 x Suction Pipe in Stainless Steel 304, DN100 Flanged
- 1 x Common Discharge Pipe in Stainless Steel 304 ended by an Expansion Joint, DN100 Flanged
- 1 x Non-Return Valve, DN100 Flanged
- 1 x Eccentric Plug Valve, DN100 Flanged
- 1 x Access Cover on the Discharge Pipe, DN50 flanged
- 1 x By-Pass Pipe in Stainless Steel 304 on the Discharge Pipe with Eccentric Plug Valve, DN50 flanged

OTHER INTERNAL EQUIPMENT

- 1 x Electrical Heating Element 750W / 1x230V with Adjustable Thermostat
- 1 x Extraction Fan (325m³/h)
- 1 x Electrical Plug CEE 2P+T 230V 16A
- 1 x Internal Lighting

ELECTRICAL BOX WITH AUTOMATIC LEVEL CONTROL (AVAILABLE AS AN OPTION)

GORMAN-RUPP EUROPE

Fahrenheitweg 35 - 8912 AK LEEUWARDEN, NL
Gutenbergweg 6 - 4104 BA CULEMBORG, NL
T. +31 582 12 37 74 - gresales@gormanruppeurope.com



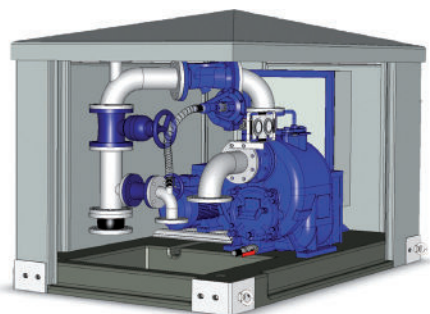
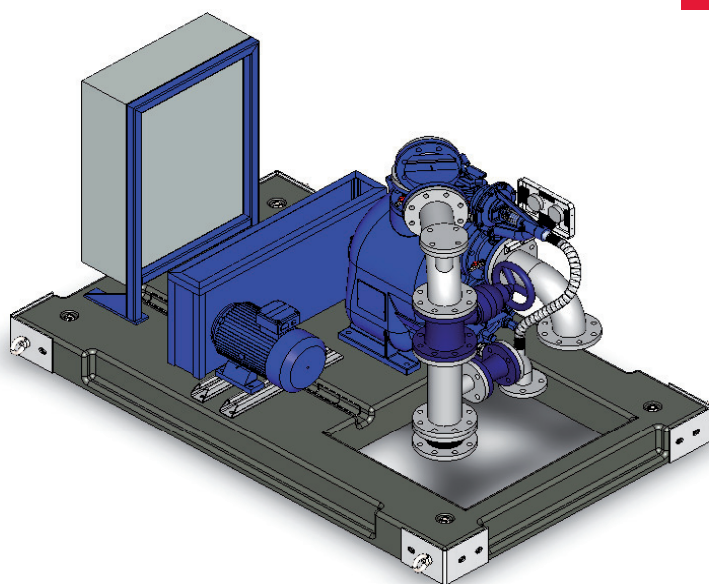
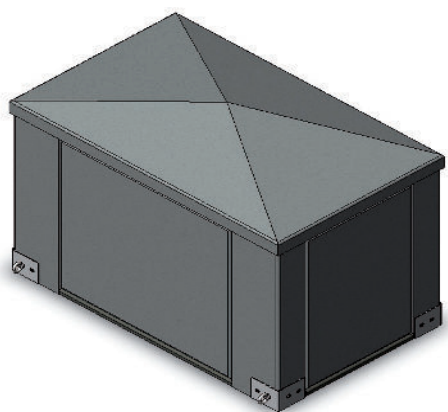

MODEL T4A-B

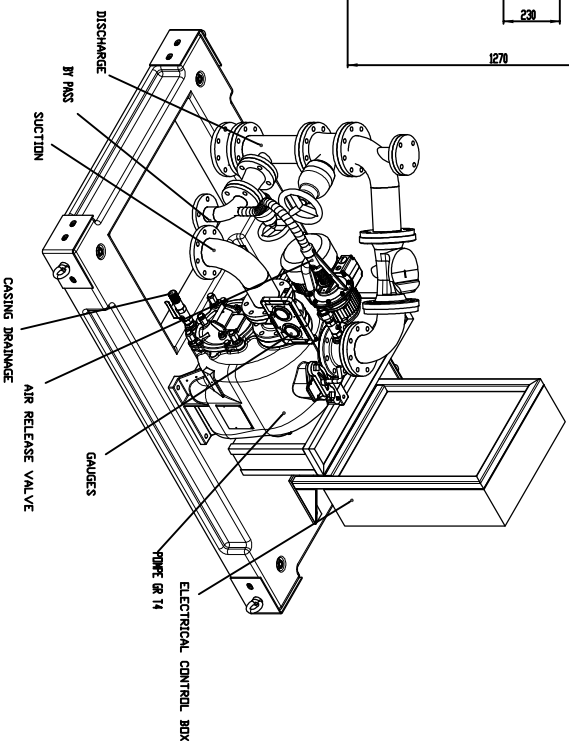
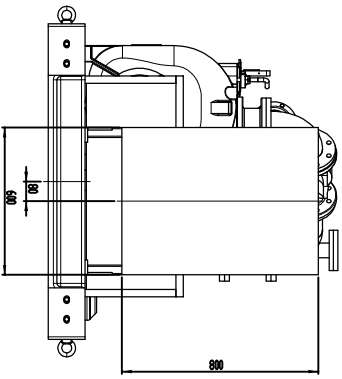
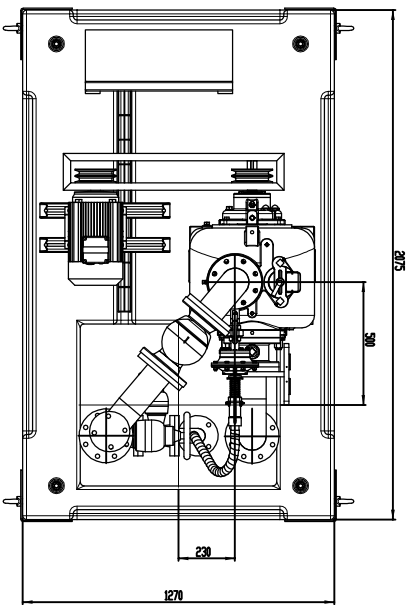
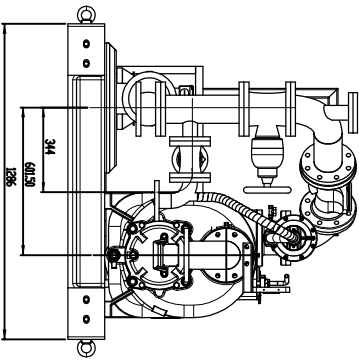
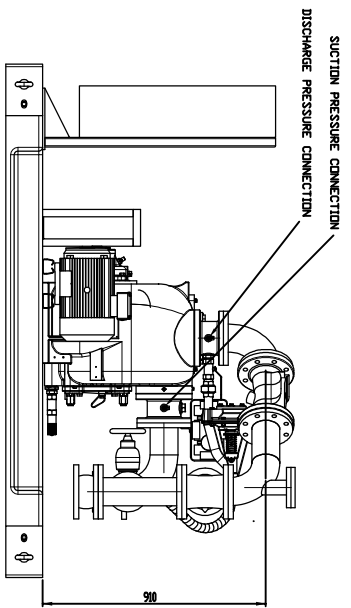
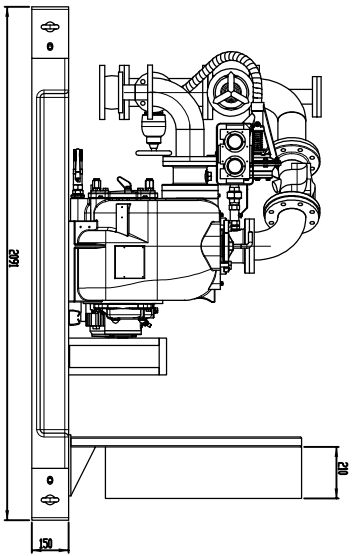

GORMAN-RUPP EUROPE

Fahrenheitweg 35 - 8912 AK LEEUWARDEN, NL
Gutenbergweg 6 - 4104 BA CULEMBORG, NL
T. +31 582 12 37 74 - gresales@gormanruppeurope.com





GERMAN-RUPP EUROPE
 GORMAN-RUPP EUROPE
 B.V.
 The Netherlands
 Tel. +31 586 12 57 74
 Fax. +31 586 12 57 57

Above Ground Lift Station
 Type 120x200
 1 x Pump Gorman-Rupp T44-B/FM

MODEL T6A-B

120 X 200 CM



FIBERGLASS ENCLOSURE

- Overall L x W x H : 2105x1300x1430mm
- Enclosure : Composite Honeycomb Sandwich Panels
- Base : Concrete covered with Polyester
- Removable Hinged Doors (External Safety Lock on two Doors)
- Removable Roof and Corners
- Four Lifting Eye Bolts
- Openings through the Base and Central Gutter for Electric Cables
- Large Groutable Opening in the Base for Pipes and Plumbing Accessories
- Ground Anchoring Provisions in the Base, for M20 Anchor Stems
- Forced Air Ventilation System
- External Gelcoat, Grey Colour RAL 7047
- Total Weight : approx. 2000 kg
- Options :
 - Soundproof Insulation
 - Brick or Stone Facings on the Doors and Corners

CUTAWAY

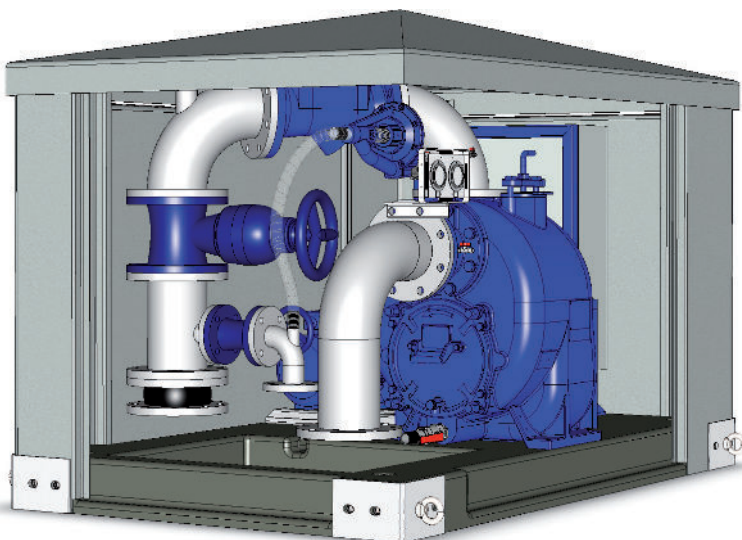

GORMAN-RUPP EUROPE

Fahrenheitweg 35 - 8912 AK LEEUWARDEN, NL
 Gutenbergweg 6 - 4104 BA CULEMBORG, NL
 T. +31 582 12 37 74 - gresales@gormanruppeurope.com

SELF PRIMING PUMP T6A-B

ES



Quantity: 1

Size: 6"x6" DN150 DIN Flanges

Maximum Capacity: 320 m³/h

Maximum Head: 32 mWC

Maximum Self Priming Lift: -7,6 m

Maximum Solids: 76 mm

Model available in Different Materials: T6A3S-B /FM, T6A60S-B /FM, T6A61S-B /FM, T6A71S-B /FM and T6A65S-B /FM. Refer to The Gorman-Rupp Specification sheet for details on the available pumps.

GRE
MAY 2012

DRIVING SYSTEM

V-belt Transmission: 1 x IEC Electrical Motor, IP55, 50 Hz, Efficiency Class IE2

Safety Transmission Guard

PUMP EQUIPMENT

- 1 x Air Release Valve Gorman-Rupp GRP 33-07 with Isolation Ball Valve and Transparent Hose
- 1 x Pump Casing High Temperature Shutdown Kit
- 1 x Suction and Discharge Pressure Gauge, mounted on a Non-Vibrating Support
- 1 x Pump Casing Drainage System, with Isolation Ball Valve and Transparent Hose

PIPINGS AND PIPING ACCESSORIES

> All Flanges are DIN PN10

- 1 x Suction Pipe in Stainless Steel 304, DN150 Flanged
- 1 x Common Discharge Pipe in Stainless Steel 304 ended by an Expansion Joint, DN150 Flanged
- 1 x Non-Return Valve, DN150 Flanged
- 1 x Eccentric Plug Valve, DN150 Flanged
- 1 x Access Cover on the Discharge Pipe, DN50 Flanged
- 1 x By-Pass Pipe in Stainless Steel 304 on the Discharge Pipe with Eccentric Plug Valve, DN50 Flanged

OTHER INTERNAL EQUIPMENT

- 1 x Electrical Heating Element 750W / 1x230V with Adjustable Thermostat
- 1 x Extraction Fan (325m³/h)
- 1 x Electrical Plug CEE 2P+T 230V 16A
- 1 x Internal Lighting

ELECTRICAL BOX WITH AUTOMATIC LEVEL CONTROL (AVAILABLE AS AN OPTION)

GORMAN-RUPP EUROPE

Fahrenheitweg 35 - 8912 AK LEEUWARDEN, NL

Gutenbergweg 6 - 4104 BA CULEMBORG, NL

T. +31 582 12 37 74 - gresales@gormanruppeurope.com

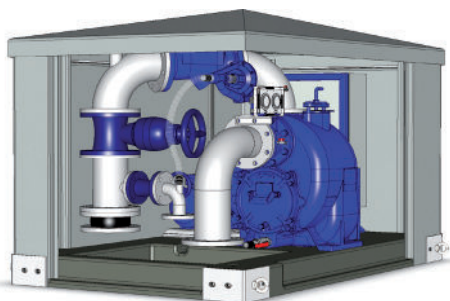
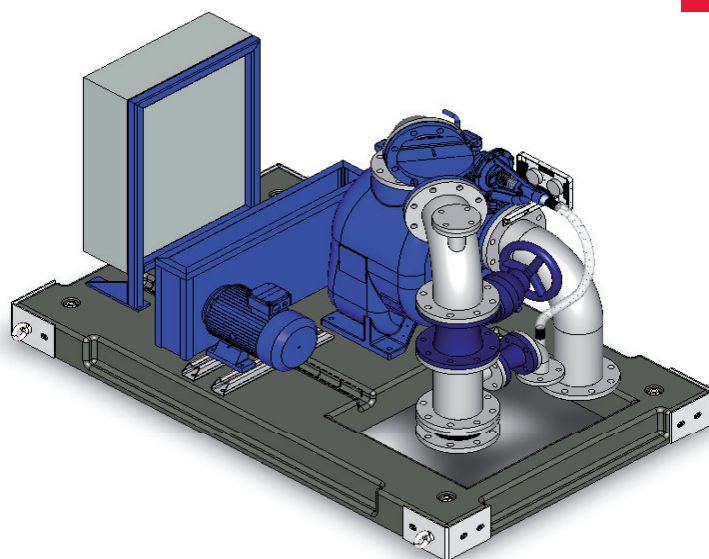
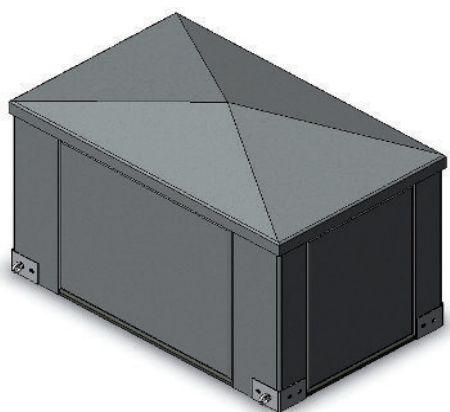

MODEL T6A-B

**GORMAN-RUPP EUROPE**

Fahrenheitweg 35 - 8912 AK LEEUWARDEN, NL
Gutenbergweg 6 - 4104 BA CULEMBORG, NL
T. +31 582 12 37 74 - gresales@gormanruppeurope.com



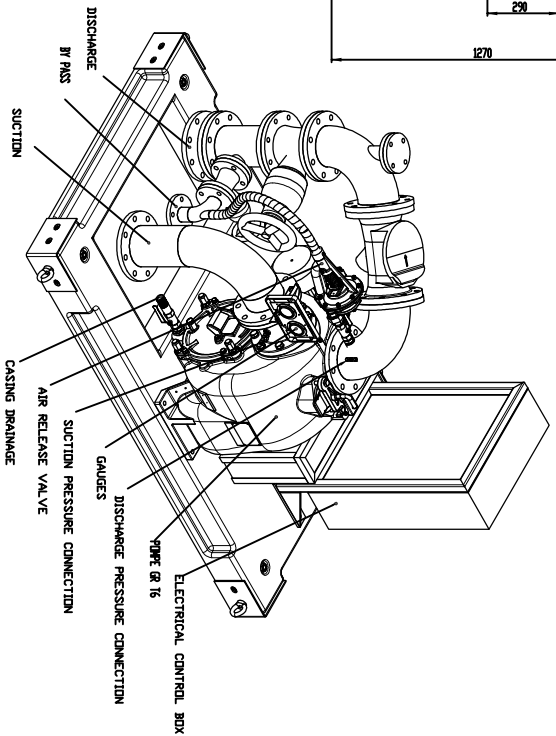
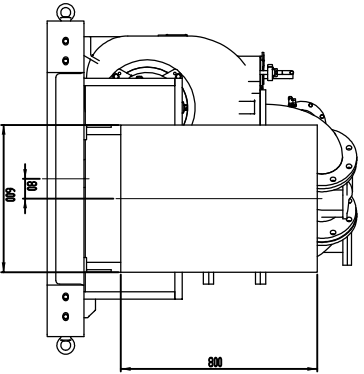
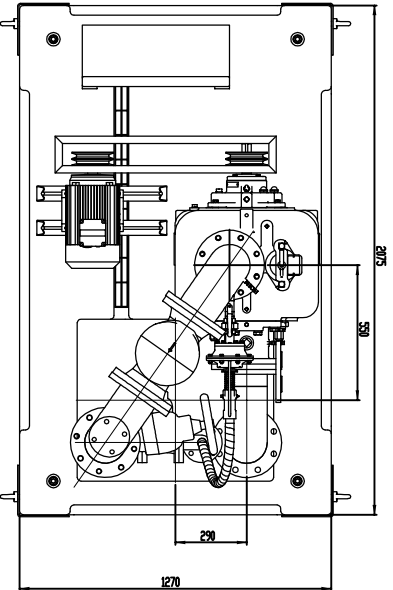
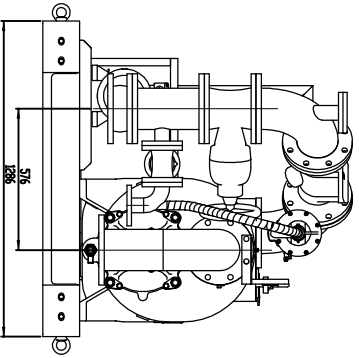
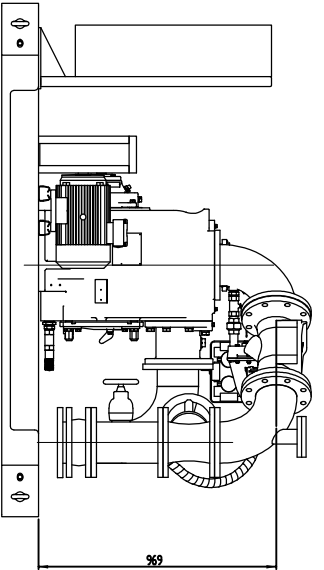
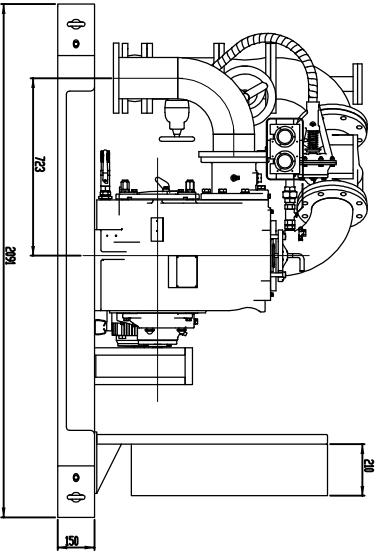

GSR
GERMAN-RUPP EUROPE
 GORMAN-RUPP B.V.
 The Netherlands
 Tel. +31 586 12 57 74
 Fax. +31 586 12 57 57

Above Ground Lift Station
 Type 120x200
 1 x Pump Gorman-Rupp T6A-B/FM

MODEL V3-B

120 X 200 CM



FIBERGLASS ENCLOSURE

- Overall L x W x H : 2105x1300x1430mm
- Enclosure : Composite Honeycomb Sandwich Panels
- Base : Concrete covered with Polyester
- Removable Hinged Doors (External Safety Lock on two Doors)
- Removable Roof and Corners
- Four Lifting Eye Bolts
- Openings through the Base and Central Gutter for Electric Cables
- Large Groutable Opening in the Base for Pipes and Plumbing Accessories
- Ground Anchoring Provisions in the Base, for M20 Anchor Stems
- Forced Air Ventilation System
- External Gelcoat, Grey Colour RAL 7047
- Total Weight : approx. 1800 kg
- Options :
 - Soundproof Insulation
 - Brick or Stone Facings on the Doors and Corners

CUTAWAY

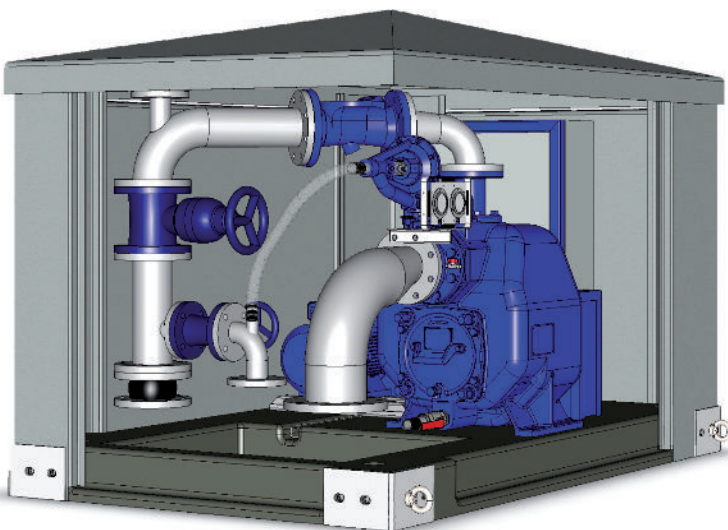

SELF PRIMING PUMP V3-B

ES



Quantity: 1

Size: 4"x3" DIN flanges

Maximum Capacity: 180 m³/h

Maximum Head: 32 mWC

Maximum Self Priming Lift: -7,6 m

Maximum Solids: 76 mm

Model available in Different Materials: V3A60-B /FM and V3B60 /FM.

Refer to The Gorman-Rupp Specification sheet for details on the available pumps.

GRE

MAY 2012

DRIVING SYSTEM

V-belt Transmission: 1 x IEC Electrical Motor, IP55, 50 Hz, Efficiency Class IE2

Safety Transmission Guard

PUMP EQUIPMENT

- 1 x Air Release Valve Gorman-Rupp GRP 33-07 with Isolation Ball Valve and Transparent Hose
- 1 x Pump Casing High Temperature Shutdown Kit
- 1 x Suction and Discharge Pressure Gauge, mounted on a Non-Vibrating Support
- 1 x Pump Casing Drainage System, with Isolation Ball Valve and Transparent Hose

PIPINGS AND PIPING ACCESSORIES

> All Flanges are DIN PN10

- 1 x Suction Pipe in Stainless Steel 304, DN150 Flanged
- 1 x Common Discharge Pipe in Stainless Steel 304 ended by an Expansion Joint, DN100 Flanged
- 1 x Non-Return Valve, DN100 Flanged
- 1 x Eccentric Plug Valve, DN100 Flanged
- 1 x Access Cover on the Discharge Pipe, DN50 Flanged
- 1 x By-Pass Pipe in Stainless Steel 304 on the Discharge Pipe with Eccentric Plug Valve, DN50 Flanged

OTHER INTERNAL EQUIPMENT

- 1 x Electrical Heating Element 750W / 1x230V with Adjustable Thermostat
- 1 x Extraction Fan (325m³/h)
- 1 x Electrical Plug CEE 2P+T 230V 16A
- 1 x Internal Lighting

ELECTRICAL BOX WITH AUTOMATIC LEVEL CONTROL (AVAILABLE AS AN OPTION)

GORMAN-RUPP EUROPE

Fahrenheitweg 35 - 8912 AK LEEUWARDEN, NL
Gutenbergweg 6 - 4104 BA CULEMBORG, NL
T. +31 582 12 37 74 - gresales@gormanruppeurope.com



MODEL V3-B

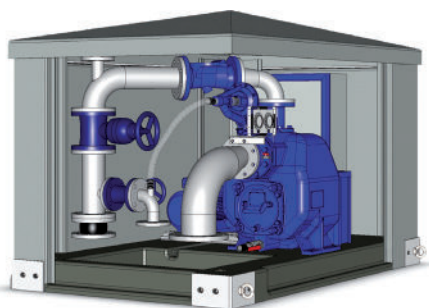
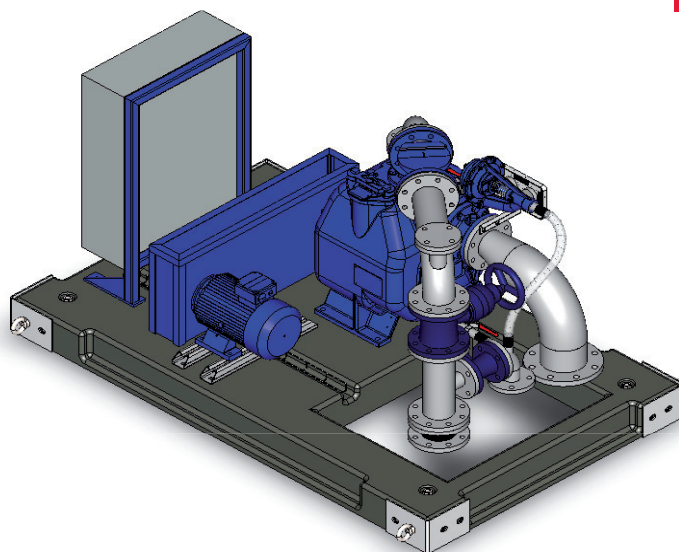
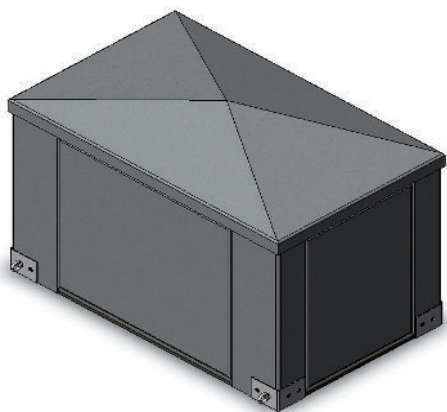

GORMAN-RUPP EUROPE

Fahrenheitweg 35 - 8912 AK LEEUWARDEN, NL
Gutenbergweg 6 - 4104 BA CULEMBORG, NL
T. +31 582 12 37 74 - gresales@gormanruppeurope.com



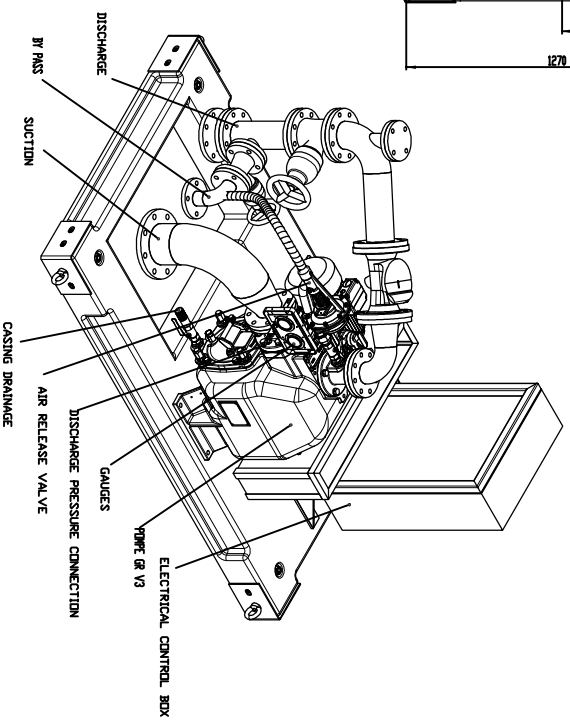
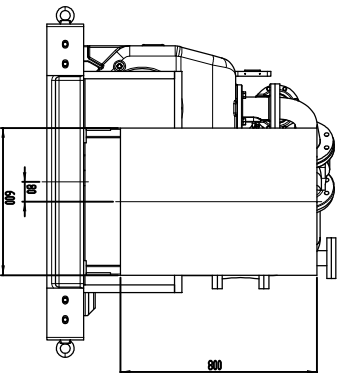
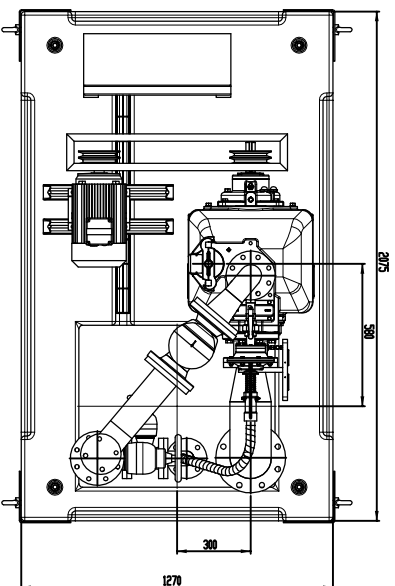
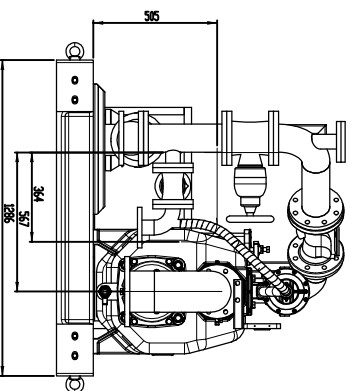
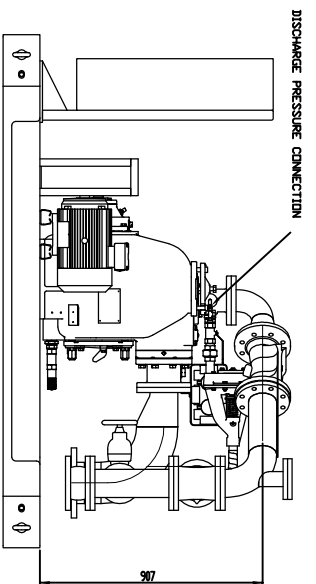
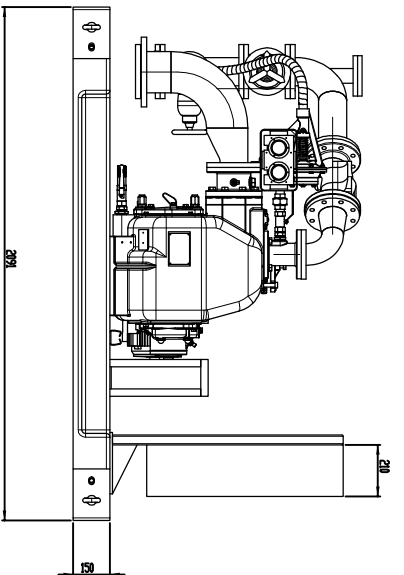



GORRAN-RUPP EUROPE

 GORRAN-RUPP B.V.

 6511 JH GORRAN-RUPP

 The Netherlands

 Tel. +31 582 12 27 74

 Fax. +31 582 12 27 57

Above Ground Lift Station

 Type 120X200

 1 x Pump Gorran-Rupp V3A-B/FM

MODEL T2A-B

200 X 200 CM



FIBERGLASS ENCLOSURE

- Overall L x W x H : 2105x2105x1430mm
- Enclosure : Composite Honeycomb Sandwich Panels
- Base : Concrete covered with Polyester
- Removable Hinged Doors (External Safety Lock on two Doors)
- Removable Roof and Corners
- Four Lifting Eye Bolts
- Openings through the Base and Central Gutter for Electric Cables
- Large Groutable Opening in the Base for Pipes and Plumbing Accessories
- Ground Anchoring Provisions in the Base, for M20 Anchor Stems
- Forced Air Ventilation System
- External Gelcoat, Grey Colour RAL 7047
- Total Weight : approx. 2000 kg
- Options :
 - Soundproof Insulation
 - Brick or Stone Facings on the Doors and Corners

CUTAWAY

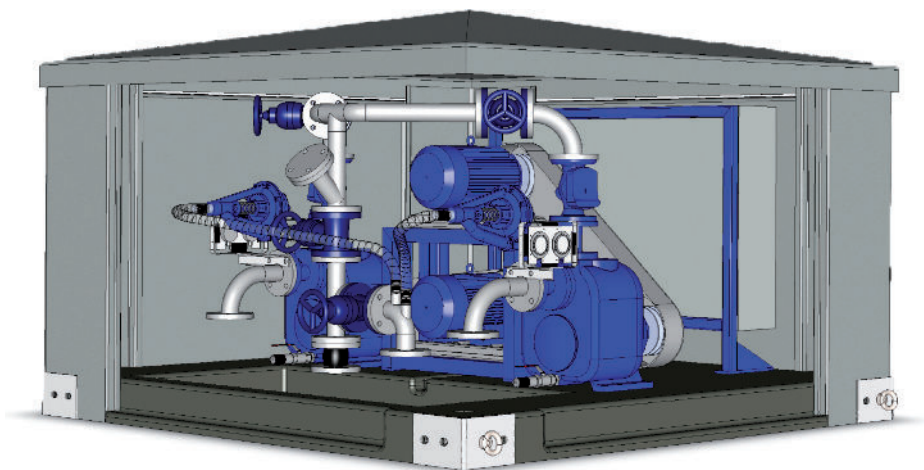

SELF PRIMING PUMP T2A-B

ES



Quantity: 2

Size: 2"x2" DN50 DIN flanges

Maximum Capacity: 50 m³/h

Maximum Head: 32 m

Maximum Self Priming Lift: -7,3 m

Maximum Solids: 38 mm

Model available in Different Materials: T2A3-B /FM, T2A60-B /FM, T2A61-B /FM, T2A71-B /FM and T2A65-B /FM. Refer to The Gorman-Rupp Specification sheet for details on the available pumps.

GRE
MAY 2012

DRIVING SYSTEM

V-belt Transmission: 2 x IEC Electrical Motors, IP55, 50 Hz, Efficiency Class IE2

Safety Transmission Guards

PUMP EQUIPMENT

- 2 x Air Release Valve Gorman-Rupp GRP 33-07 with Isolation Ball Valve and Transparent Hose
- 2 x Pump Casing High Temperature Shutdown Kit
- 2 x Suction and Discharge Pressure Gauge, mounted on a Non-Vibrating Support
- 2 x Pump Casing Drainage System, with Isolation Ball Valve and Transparent Hose

PIPINGS AND PIPING ACCESSORIES

> All Flanges are DIN PN10

- 2 x Suction Pipe in Stainless Steel 304, DN50 Flanged
- 1 x Common Discharge Pipe in Stainless Steel 304 ended by an Expansion Joint, DN50 Flanged
- 2 x Non-Return Valve, DN50 Flanged
- 3 x Eccentric Plug Valve, DN50 Flanged
- 1 x Access Cover on the Discharge Pipe, DN50 Flanged
- 1 x By-Pass Pipe in Stainless Steel 304 on the Discharge Pipe with Eccentric Plug Valve, DN50 Flanged

OTHER INTERNAL EQUIPMENT

- 1 x Electrical Heating Element 750W / 1x230V with Adjustable Thermostat
- 1 x Extraction Fan (325m³/h)
- 1 x Electrical Plug CEE 2P+T 230V 16A
- 1 x Internal Lighting

ELECTRICAL BOX WITH AUTOMATIC LEVEL CONTROL (AVAILABLE AS AN OPTION)

GORMAN-RUPP EUROPE

Fahrenheitweg 35 - 8912 AK LEEUWARDEN, NL

Gutenbergweg 6 - 4104 BA CULEMBORG, NL

T. +31 582 12 37 74 - gresales@gormanruppeurope.com



MODEL T2A-B

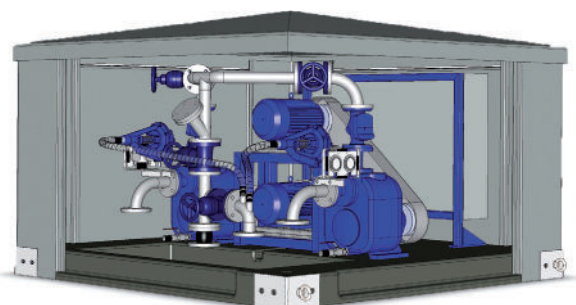
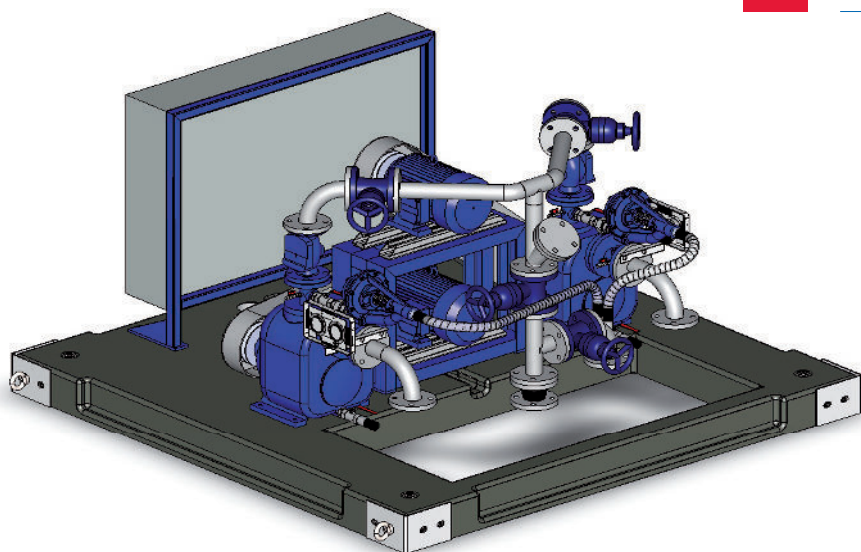
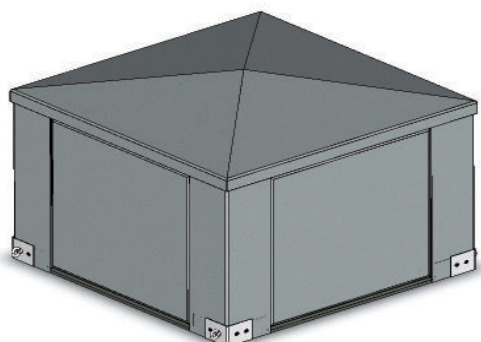

GORMAN-RUPP EUROPE

Fahrenheitweg 35 - 8912 AK LEEUWARDEN, NL
Gutenbergweg 6 - 4104 BA CULEMBORG, NL
T. +31 582 12 37 74 - gresales@gormanruppeurope.com



MODEL T3A-B

200 X 200 CM



FIBERGLASS ENCLOSURE

- Overall L x W x H : 2105x2105x1430mm
- Enclosure : Composite Honeycomb Sandwich Panels
- Base : Concrete covered with Polyester
- Removable Hinged Doors (External Safety Lock on two Doors)
- Removable Roof and Corners
- Four Lifting Eye Bolts
- Openings through the Base and Central Gutter for Electric Cables
- Large Groutable Opening in the Base for Pipes and Plumbing Accessories
- Ground Anchoring Provisions in the Base, for M20 Anchor Stems
- Forced Air Ventilation System
- External Gelcoat, Grey Colour RAL 7047
- Total Weight : approx. 2200 kg
- Options :
 - Soundproof Insulation
 - Brick or Stone Facings on the Doors and Corners

CUTAWAY

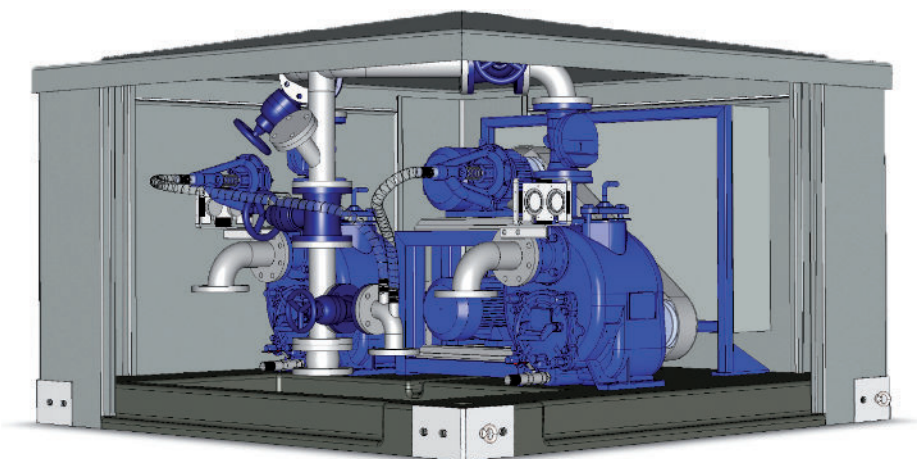

SELF PRIMING PUMP T3A-B

ES



Quantity: 2

Size: 3"x3" DN80 DIN Flanges

Maximum Capacity: 100 m³/h

Maximum Head: 34 m

Maximum Self Priming Lift: -7,6 m

Maximum Solids: 63 mm

Model available in Different Materials: T3A3S-B /FM, T3A60S-B /FM, T3A61S-B /FM, T3A71S-B /FM and T3A65S-B /FM. Refer to The Gorman-Rupp Specification sheet for details on the available pumps.

GRE
MAY 2012

DRIVING SYSTEM

V-belt Transmission: 2 x IEC Electrical Motors, IP55, 50 Hz, Efficiency Class IE2

Safety Transmission Guards

PUMP EQUIPMENT

- 2 x Air Release Valve Gorman-Rupp GRP 33-07 with Isolation Ball Valve and Transparent Hose
- 2 x Pump Casing High Temperature Shutdown Kit
- 2 x Suction and Discharge Pressure Gauge, mounted on a Non-Vibrating Support
- 2 x Pump Casing Drainage System, with Isolation Ball Valve and Transparent Hose

PIPINGS AND PIPING ACCESSORIES

> All Flanges are DIN PN10

- 2 x Suction Pipe in Stainless Steel 304, DN80 Flanged
- 1 x Common Discharge Pipe in Stainless Steel 304 ended by an Expansion Joint, DN80 Flanged
- 2 x Non-Return Valve, DN80 Flanged
- 3 x Eccentric Plug Valve, DN80 Flanged
- 1 x Access Cover on the Discharge Pipe, DN50 Flanged
- 1 x By-Pass Pipe in Stainless Steel 304 on the Discharge Pipe with Eccentric Plug Valve, DN50 Flanged

OTHER INTERNAL EQUIPMENT

- 1 x Electrical Heating Element 750W / 1x230V with Adjustable Thermostat
- 1 x Extraction Fan (325m³/h)
- 1 x Electrical Plug CEE 2P+T 230V 16A
- 1 x Internal Lighting

ELECTRICAL BOX WITH AUTOMATIC LEVEL CONTROL (AVAILABLE AS AN OPTION)

GORMAN-RUPP EUROPE

Fahrenheitweg 35 - 8912 AK LEEUWARDEN, NL

Gutenbergweg 6 - 4104 BA CULEMBORG, NL

T. +31 582 12 37 74 - gresales@gormanruppeurope.com

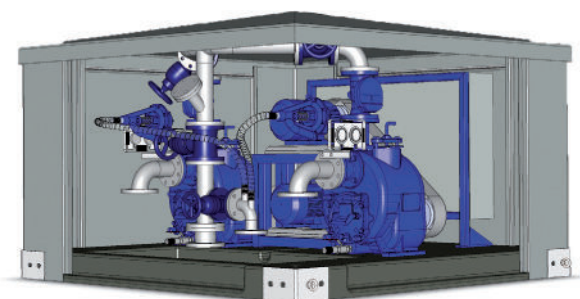
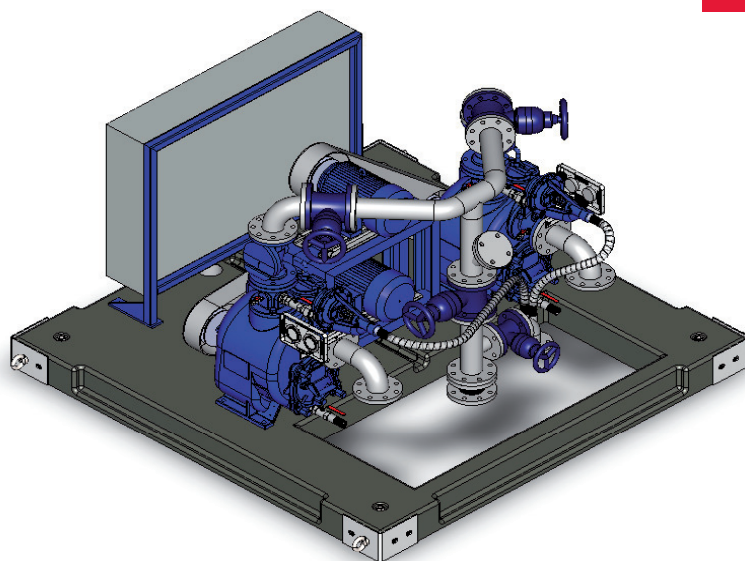
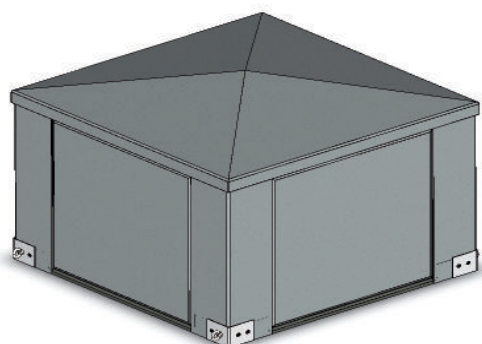

MODEL T3A-B

**GORMAN-RUPP EUROPE**

Fahrenheitweg 35 - 8912 AK LEEUWARDEN, NL
Gutenbergweg 6 - 4104 BA CULEMBORG, NL
T. +31 582 12 37 74 - gresales@gormanruppeurope.com

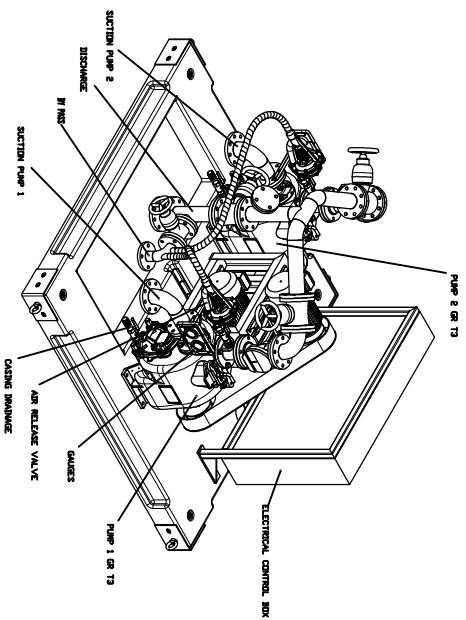
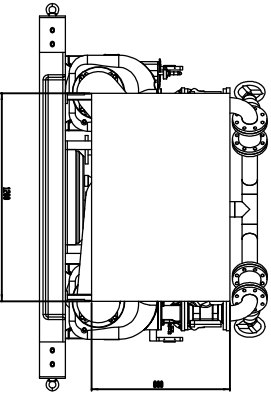
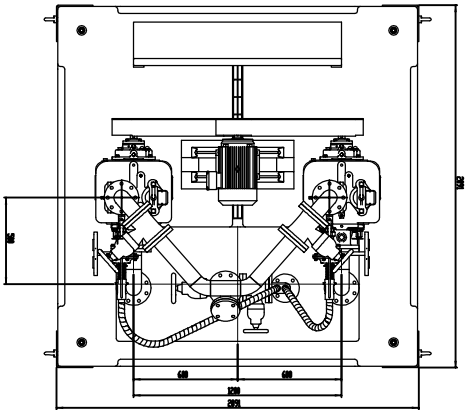
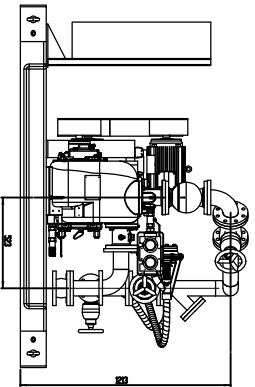
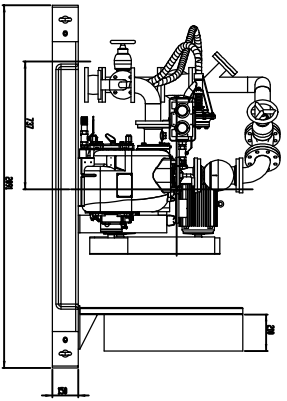

GERMAN-RUPP EUROPE
 P.O. Box 100
 8912 AK Lelystad
 The Netherlands 74
 Tel. +31 362 15 97 74
 Fax. +31 362 15 90 57

Above Ground Lift Station
 Type E20X200 T3A-B/FM
 2 x Pump Gorman-Rupp

MODEL T4A-B

200 X 200 CM



FIBERGLASS ENCLOSURE

- Overall L x W x H : 2105x2105x1430mm
- Enclosure : Composite Honeycomb Sandwich Panels
- Base : Concrete covered with Polyester
- Removable Hinged Doors (External Safety Lock on two Doors)
- Removable Roof and Corners
- Four Lifting Eye Bolts
- Openings through the Base and Central Gutter for Electric Cables
- Large Groutable Opening in the Base for Pipes and Plumbing Accessories
- Ground Anchoring Provisions in the Base, for M20 Anchor Stems
- Forced Air Ventilation System
- External Gelcoat, Grey Colour RAL 7047
- Total Weight : approx. 2400 kg
- Options :
 - Soundproof Insulation
 - Brick or Stone Facings on the Doors and Corners

CUTAWAY

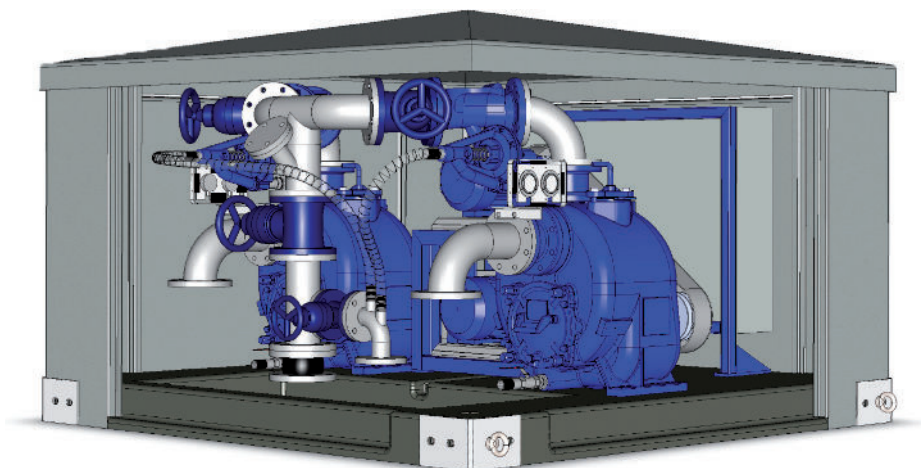

SELF PRIMING PUMP T4A-B

ES



Quantity: 2

Size: 4"x4" DN100 DIN Flanges

Maximum Capacity: 160 m³/h

Maximum Head: 34 m

Maximum Self Priming Lift: -7,6 m

Maximum Solids: 76 mm

Model available in Different Materials: T4A3S-B /FM, T4A60S-B /FM, T4A61S-B /FM, T4A71S-B /FM and T4A65S-B /FM. Refer to The Gorman-Rupp Specification sheet for details on the available pumps.

GRE
MAY 2012

DRIVING SYSTEM

V-belt Transmission: 2 x IEC Electrical Motors, IP55, 50 Hz, Efficiency Class IE2

Safety Transmission Guards

PUMP EQUIPMENT

- 2 x Air Release Valve Gorman-Rupp GRP 33-07 with Isolation Ball Valve and Transparent Hose
- 2 x Pump Casing High Temperature Shutdown Kit
- 2 x Suction and Discharge Pressure Gauge, mounted on a Non-Vibrating Support
- 2 x Pump Casing Drainage System, with Isolation Ball Valve and Transparent Hose

PIPINGS AND PIPING ACCESSORIES

> All Flanges are DIN PN10

- 2 x Suction Pipe in Stainless Steel 304, DN100 Flanged
- 1 x Common Discharge Pipe in Stainless Steel 304 ended by an Expansion Joint, DN100 Flanged
- 2 x Non-Return Valve, DN100 Flanged
- 3 x Eccentric Plug Valve, DN100 Flanged
- 1 x Access Cover on the Discharge Pipe, DN50 Flanged
- 1 x By-Pass Pipe in Stainless Steel 304 on the Discharge Pipe with Eccentric Plug Valve, DN50 Flanged

OTHER INTERNAL EQUIPMENT

- 1 x Electrical Heating Element 750W / 1x230V with Adjustable Thermostat
- 1 x Extraction Fan (325m³/h)
- 1 x Electrical Plug CEE 2P+T 230V 16A
- 1 x Internal Lighting

ELECTRICAL BOX WITH AUTOMATIC LEVEL CONTROL (AVAILABLE AS AN OPTION)

GORMAN-RUPP EUROPE

Fahrenheitweg 35 - 8912 AK LEEUWARDEN, NL

Gutenbergweg 6 - 4104 BA CULEMBORG, NL

T. +31 582 12 37 74 - gresales@gormanruppeurope.com



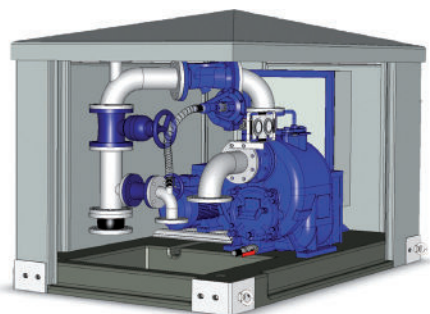
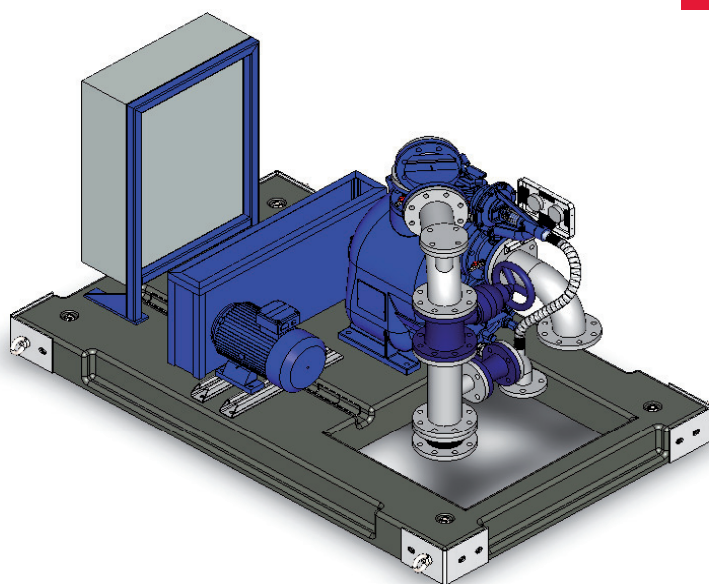
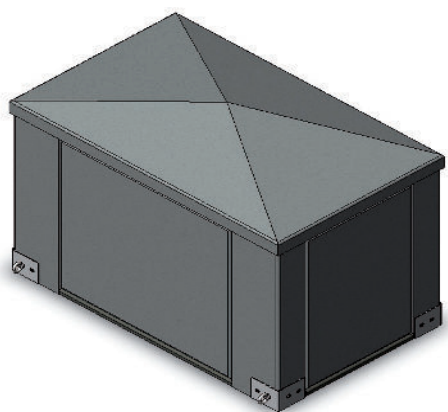

MODEL T4A-B

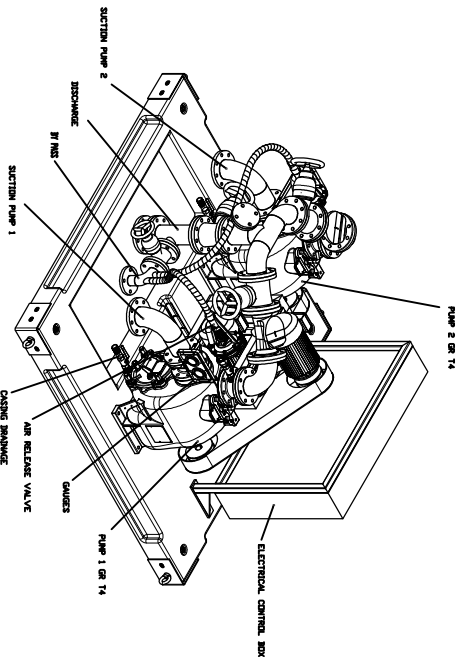
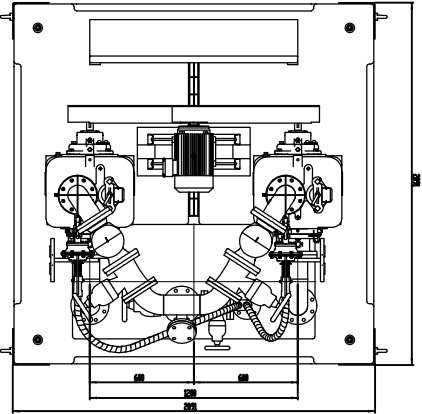
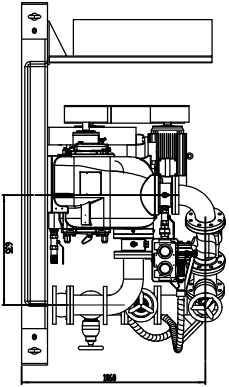
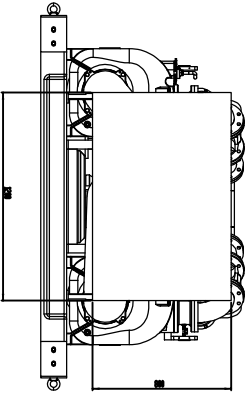
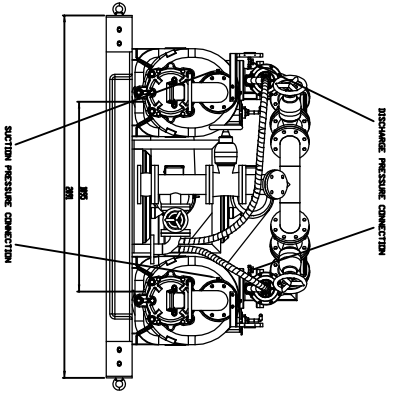
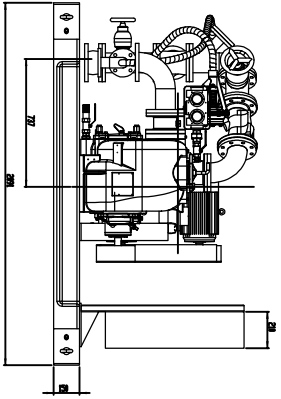

GORMAN-RUPP EUROPE

Fahrenheitweg 35 - 8912 AK LEEUWARDEN, NL
Gutenbergweg 6 - 4104 BA CULEMBORG, NL
T. +31 582 12 37 74 - gresales@gormanruppeurope.com





 GORMAN-RUPP EUROPE

 P.O. Box 100

 8912 AK Lelystad

 The Netherlands

 Tel. +31 526 15 97 74

 Fax. +31 526 15 80 57

Above Ground Lift Station

 Type E20X200 14A-B/FM

 2 x Pump Gorman-Rupp

MODEL T6A-B

200 X 200 CM



FIBERGLASS ENCLOSURE

- Overall L x W x H : 2105x2105x1430mm
- Enclosure : Composite Honeycomb Sandwich Panels
- Base : Concrete covered with Polyester
- Removable Hinged Doors (External Safety Lock on two Doors)
- Removable Roof and Corners
- Four Lifting Eye Bolts
- Openings through the Base and Central Gutter for Electric Cables
- Large Groutable Opening in the Base for Pipes and Plumbing Accessories
- Ground Anchoring Provisions in the Base, for M20 Anchor Stems
- Forced Air Ventilation System
- External Gelcoat, Grey Colour RAL 7047
- Total Weight : approx. 2800 kg
- Options :
 - Soundproof Insulation
 - Brick or Stone Facings on the Doors and Corners

CUTAWAY

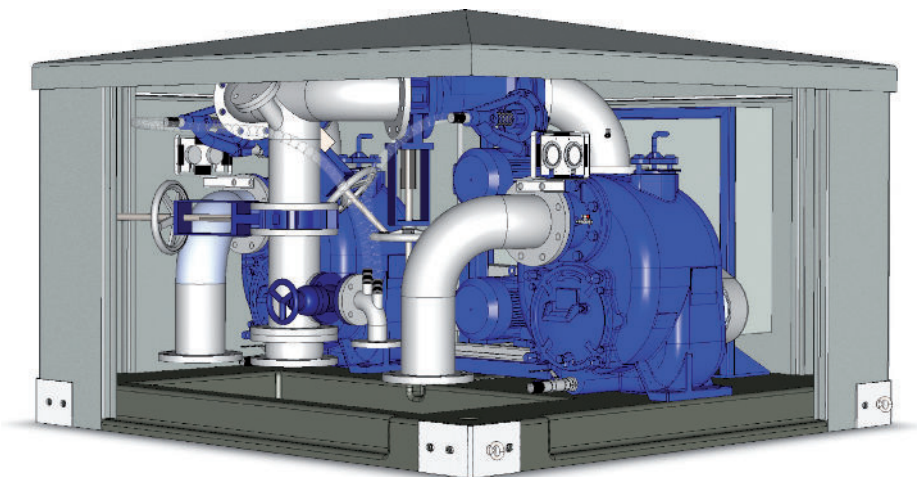

SELF PRIMING PUMP T6A-B

ES



Quantity: 2

Size: 6"x6" DN150 DIN Flanges

Maximum Capacity: 320 m³/h

Maximum Head: 32 m

Maximum Self Priming Lift: -7,6 m

Maximum Solids: 76 mm

Model available in Different Materials: T6A3S-B /FM, T6A60S-B /FM, T6A61S-B /FM, T6A71S-B /FM and T6A65S-B /FM. Refer to The Gorman-Rupp Specification sheet for details on the available pumps.

GRE
MAY 2012

DRIVING SYSTEM

V-belt Transmission: 2 x IEC Electrical Motors, IP55, 50 Hz, Efficiency Class IE2

Safety Transmission Guards

PUMP EQUIPMENT

- 2 x Air Release Valve Gorman-Rupp GRP 33-07 with Isolation Ball Valve and Transparent Hose
- 2 x Pump Casing High Temperature Shutdown Kit
- 2 x Suction and Discharge Pressure Gauge, mounted on a Non-Vibrating Support
- 2 x Pump Casing Drainage System, with Isolation Ball Valve and Transparent Hose

PIPINGS AND PIPING ACCESSORIES

> All Flanges are DIN PN10

- 2 x Suction Pipe in Stainless Steel 304, DN150 Flanged
- 1 x Common Discharge Pipe in Stainless Steel 304 ended by an Expansion Joint, DN150 Flanged
- 2 x Non-Return Valve, DN150 Flanged
- 3 x Eccentric Plug Valve, DN150 Flanged
- 1 x Access Cover on the Discharge Pipe, DN50 Flanged
- 1 x By-Pass Pipe in Stainless Steel 304 on the Discharge Pipe with Eccentric Plug Valve, DN50 Flanged

OTHER INTERNAL EQUIPMENT

- 1 x Electrical Heating Element 750W / 1x230V with Adjustable Thermostat
- 1 x Extraction Fan (325m³/h)
- 1 x Electrical Plug CEE 2P+T 230V 16A
- 1 x Internal Lighting

ELECTRICAL BOX WITH AUTOMATIC LEVEL CONTROL (AVAILABLE AS AN OPTION)

GORMAN-RUPP EUROPE

Fahrenheitweg 35 - 8912 AK LEEUWARDEN, NL

Gutenbergweg 6 - 4104 BA CULEMBORG, NL

T. +31 582 12 37 74 - gresales@gormanruppeurope.com



MODEL T6A-B

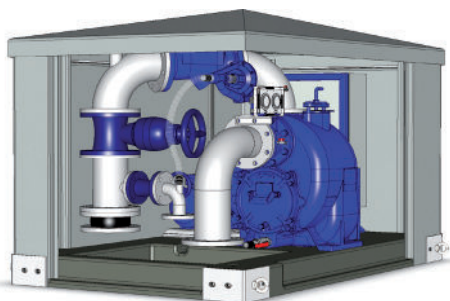
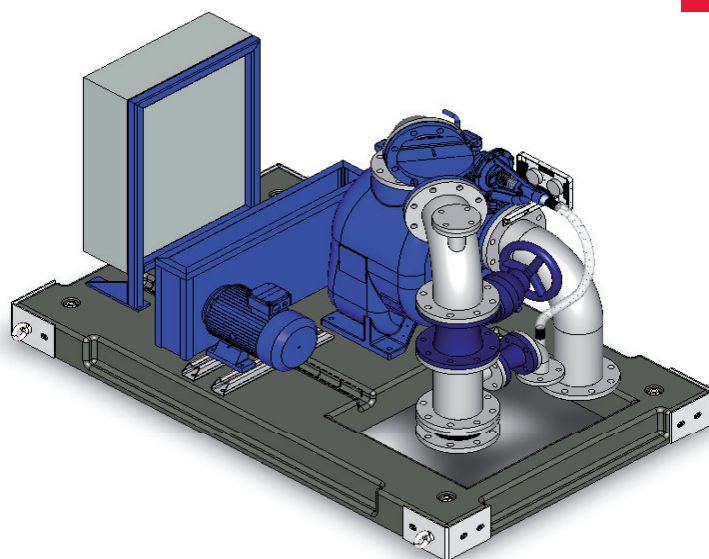
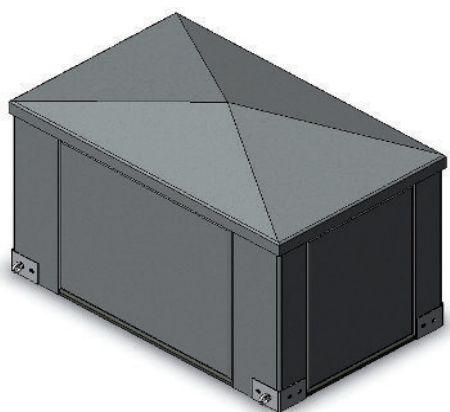

GORMAN-RUPP EUROPE

Fahrenheitweg 35 - 8912 AK LEEUWARDEN, NL
Gutenbergweg 6 - 4104 BA CULEMBORG, NL
T. +31 582 12 37 74 - gresales@gormanruppeurope.com



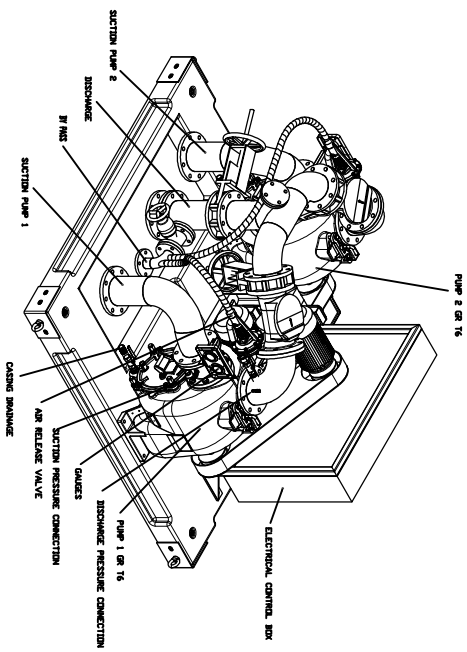
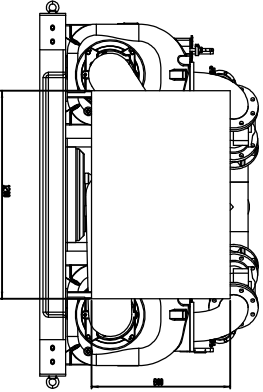
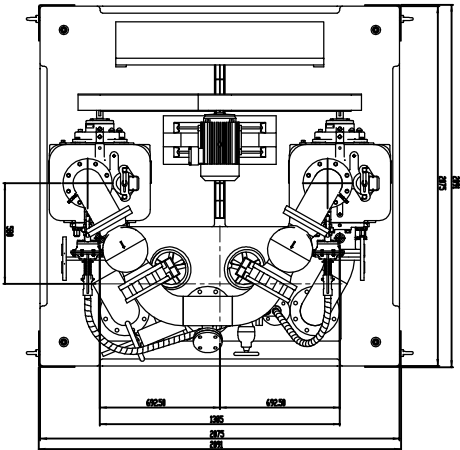
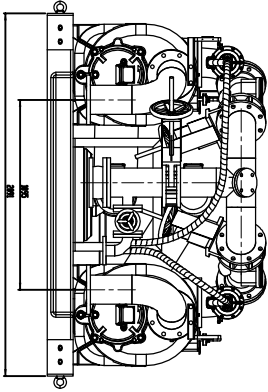
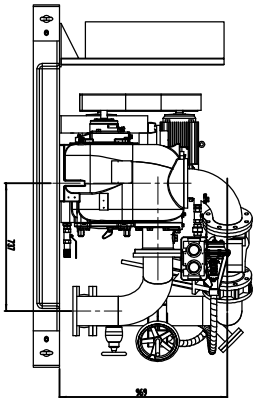
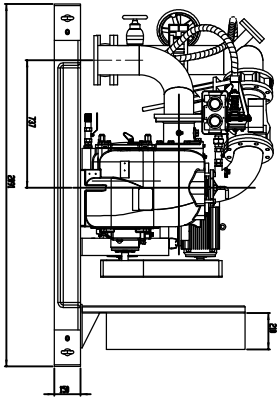

GORMAN-RUPP EUROPE
 A Division of
 GORMAN-RUPP
 8912 AK Lissewoude
 The Netherlands 74
 Tel. +31 595 15 97 74
 Fax. +31 595 15 80 57

Above Ground Lift Station
 Type E20X200 T6A-B/FM
 2 x Pump Gorman-Rupp

MODEL V3-B

200 X 200 CM



FIBERGLASS ENCLOSURE

- Overall L x W x H : 2105x2105x1430mm
- Enclosure : Composite Honeycomb Sandwich Panels
- Base : Concrete covered with Polyester
- Removable Hinged Doors (External Safety Lock on two Doors)
- Removable Roof and Corners
- Four Lifting Eye Bolts
- Openings through the Base and Central Gutter for Electric Cables
- Large Groutable Opening in the Base for Pipes and Plumbing Accessories
- Ground Anchoring Provisions in the Base, for M20 Anchor Stems
- Forced Air Ventilation System
- External Gelcoat, Grey Colour RAL 7047
- Total Weight : approx. 2500 kg
- Options :
 - Soundproof Insulation
 - Brick or Stone Facings on the Doors and Corners

CUTAWAY

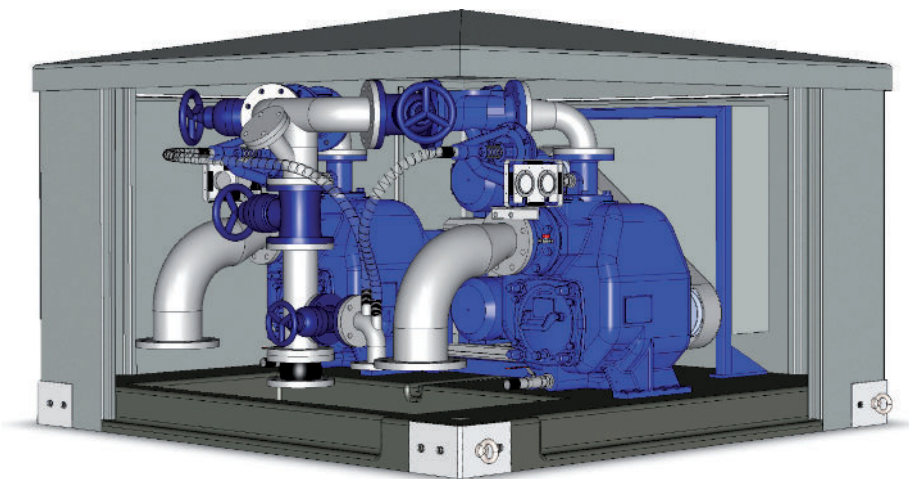

SELF PRIMING PUMP V3-B

ES



Quantity: 2

Size: 4"x3" DIN Flanges

Maximum Capacity: 180 m³/h

Maximum Head: 32 m

Maximum Self Priming Lift: -7,6 m

Maximum Solids: 76 mm

Model available in Different Materials: V3A60-B /FM and V3B60 /FM.

Refer to The Gorman-Rupp Specification sheet for details on the available pumps.

GRE

MAY 2012

DRIVING SYSTEM

V-belt Transmission: 2 x IEC Electrical Motors, IP55, 50 Hz, Efficiency Class IE2

Safety Transmission Guards

PUMP EQUIPMENT

- 2 x Air Release Valve Gorman-Rupp GRP 33-07 with Isolation Ball Valve and Transparent Hose
- 2 x Pump Casing High Temperature Shutdown Kit
- 2 x Suction and Discharge Pressure Gauge, mounted on a Non-Vibrating Support
- 2 x Pump Casing Drainage System, with Isolation Ball Valve and Transparent Hose

PIPINGS AND PIPING ACCESSORIES

> All Flanges are DIN PN10

- 2 x Suction Pipe in Stainless Steel 304, DN150 Flanged
- 1 x Common Discharge Pipe in Stainless Steel 304 ended by an Expansion Joint, DN100 Flanged
- 2 x Non-Return Valve, DN100 Flanged
- 3 x Eccentric Plug Valve, DN100 Flanged
- 1 x Access Cover on the Discharge Pipe, DN50 Flanged
- 1 x By-Pass Pipe in Stainless Steel 304 on the Discharge Pipe with Eccentric Plug Valve, DN50 Flanged

OTHER INTERNAL EQUIPMENT

- 1 x Electrical Heating Element 750W / 1x230V with Adjustable Thermostat
- 1 x Extraction Fan (325m³/h)
- 1 x Electrical Plug CEE 2P+T 230V 16A
- 1 x Internal Lighting

ELECTRICAL BOX WITH AUTOMATIC LEVEL CONTROL (AVAILABLE AS AN OPTION)

GORMAN-RUPP EUROPE

Fahrenheitweg 35 - 8912 AK LEEUWARDEN, NL

Gutenbergweg 6 - 4104 BA CULEMBORG, NL

T. +31 582 12 37 74 - gresales@gormanruppeurope.com



MODEL V3-B

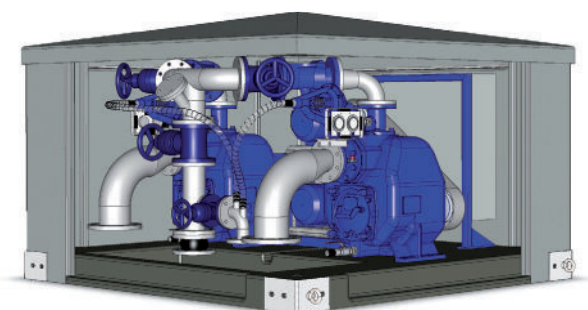
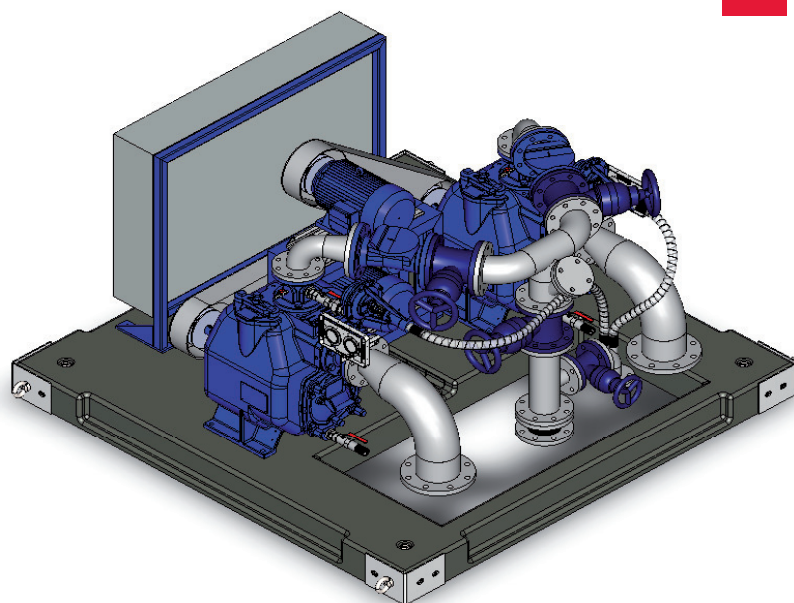
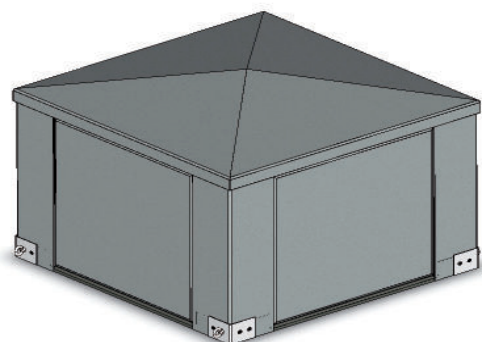

GORMAN-RUPP EUROPE

Fahrenheitweg 35 - 8912 AK LEEUWARDEN, NL
Gutenbergweg 6 - 4104 BA CULEMBORG, NL
T. +31 582 12 37 74 - gresales@gormanruppeurope.com

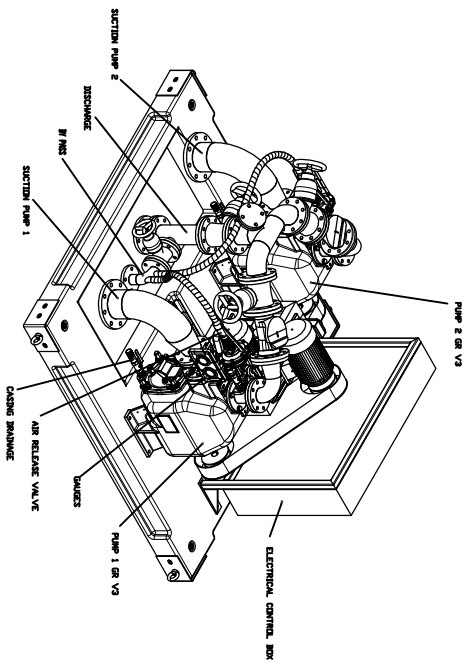
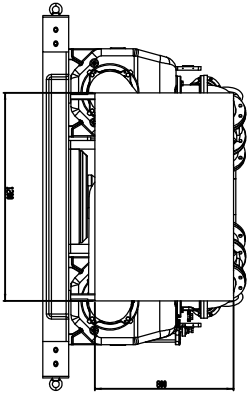
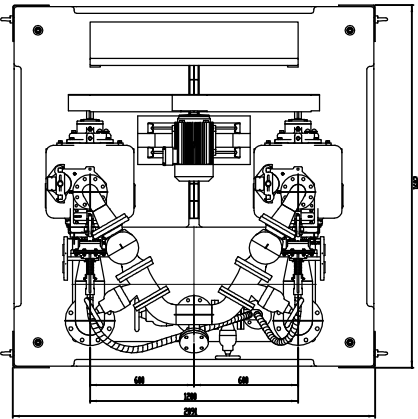
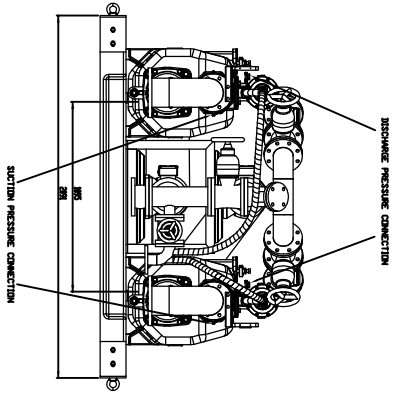
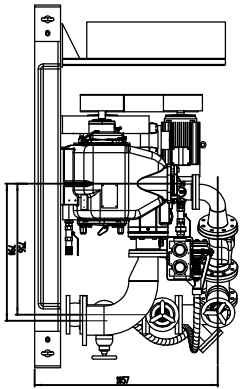
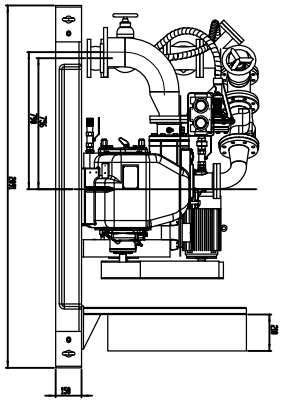

GORMAN-RUPP EUROPE
 8912 AK Lelystad
 The Netherlands 74
 Tel. +31 362 15 97 74
 Fax. +31 362 15 80 57

Above Ground Lift Station
 Type E20X200
 2 x Pump Gorman-Rupp V3A-B/FM