

DESMI self-priming centrifugal pump

MODULAR S

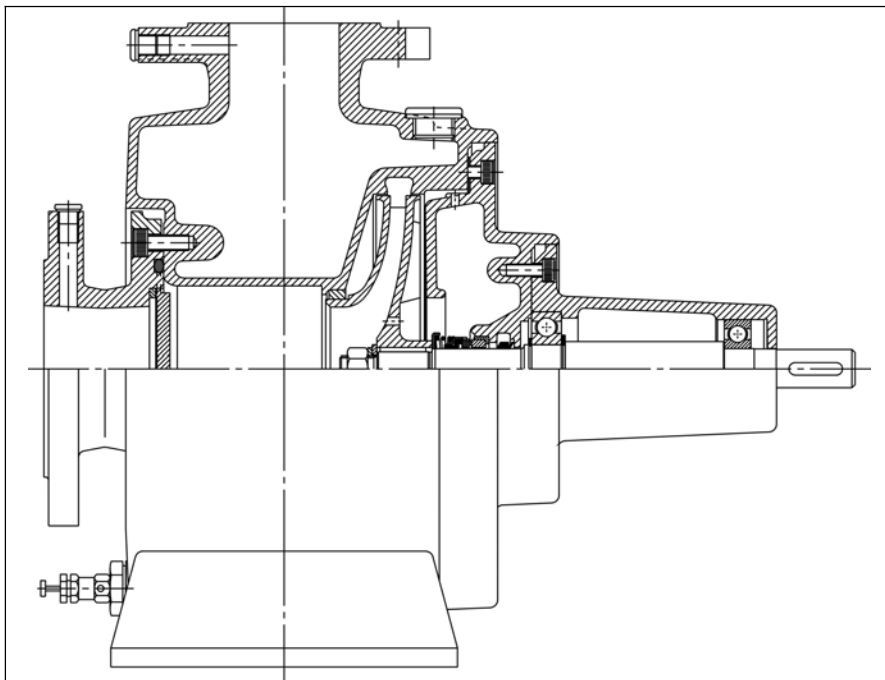

**DESMI A/S**

Tagholm 1, DK-9400 Nørresundby Phone +45 96 32 81 11 Fax +45 98 17 54 99

Manual: T1339	Language: English	Revision: F (05/02)
------------------	----------------------	------------------------

Special pump No.....



<b>TABLE OF CONTENTS:</b>	<b>PAGE</b>
1. PRODUCT DESCRIPTION.....	3
1.1 DELIVERY.....	3
2. TECHNICAL DATA .....	3
2.1 EXPLANATION OF THE TYPE NUMBER.....	3
2.2 TECHNICAL DESCRIPTION .....	4
3. INSTALLATION .....	6
3.1 MOUNTING/FASTENING.....	6
3.2 WIRING.....	7
4. TRANSPORT/ STORAGE .....	7
5. DISMANTLING .....	8
5.1 ACCESS TO IMPELLER AND SHAFT SEAL.....	8
5.2 DISMANTLING SHAFT SEAL .....	8
5.3 DISMANTLING SEAT .....	8
5.4 DISMANTLING SHAFT WITH BEARINGS .....	8
5.5 INSPECTION .....	8
6. ASSEMBLING.....	9
6.1 FITTING SEALING RING IN PUMP CASING.....	9
6.2 FITTING SHAFT WITH BEARINGS .....	9
6.3 FITTING WATER DEFLECTOR.....	9
6.4 FITTING SHAFT SEAL.....	9
6.5 FITTING IMPELLER.....	9
6.6 FITTING GUIDE RING AND GUIDE VANE PIECE (ONLY S-32-25-110).....	9
6.7 FITTING BEARING HOUSING AND SHAFT SEAL COVER.....	10
6.8 SHAFT .....	10
7. FROST PROTECTION.....	10
8. DISMANTLING .....	10
9. START-UP .....	10
9.1 STARTING.....	11
10. SYSTEM BALANCING.....	11
11. INSPECTION AND MAINTENANCE.....	13
11.1 DRAINING THE PUMP .....	13
11.2 BEARINGS.....	13
12. REPAIRS.....	13
12.1 ORDERING SPARE PARTS .....	13
13. OPERATING DATA .....	13
14. EU DECLARATION OF CONFORMITY.....	15
15. ASSEMBLY DRAWINGS .....	16
16. SPARE PARTS LISTS.....	16
17. DIMENSIONAL SKETCH.....	19

## 1. PRODUCT DESCRIPTION

These operation and maintenance instructions apply to the DESMI MODULAR S pump series. The pumps are available in sizes ranging from 25 to 100 mm on the pressure flange. The suction flange is bigger than the pressure flange.

DESMI S is a single-stage self-priming centrifugal pump with stainless steel shaft and mechanical shaft seal. The smallest pumps, S-32-25-110 and S-50-32-135, have open impeller, whereas all other sizes have closed impeller.

The pump is suitable for the pumping of clean and polluted liquids with temperatures between 0 and 80°C. With special shaft seal up to 140°C. Max. number of revolutions: 3600 RPM.

The pump has horizontal inlet on the centre line and vertical outlet at the top.

The back of the impeller is equipped with relief blades to reduce the load on the bearings.

Relief holes in the impeller ensure circulation of liquid for the shaft seal and prevent overheating of the shaft seal during normal operation.

The pump is particularly suitable for the pumping of water in connection with e.g. cooling of diesel engines, as bilge pumps, ballast pumps, pumps for irrigation, washing plants, air conditioning, cooling systems, and sanitary systems, etc. Furthermore, in the majority of cases where the transport of liquid is required within industry.

### 1.1 DELIVERY

- Check on delivery that the shipment is complete and undamaged.
- Defects and damages, if any, to be reported to the carrier and the supplier immediately in order that a claim can be advanced.

## 2. TECHNICAL DATA

The pumps are manufactured in various material combinations which appear from the type number on the name plate. See below.

### 2.1 EXPLANATION OF THE TYPE NUMBER

All the S pumps are provided with a nameplate. The type number indicated on the nameplate is built up as follows:

S-XXX-YYY-ZZZ-MR

XXX, YYY, ZZZ : Pump size where

XXX = Suction branch diameter, YYY= Pressure branch diameter,  
ZZZ = Standard impeller diameter.

M : The material combination of the pump.

R : The assembly combination of the pump.

M may be the following:

- A : Standard. Casing: GG20. Impeller: AlBz.
- C : All cast iron.
- D : Casing: BSP5, Impeller: AlBz.
- E : Special alloy.

The pumps can be delivered in other material combinations which are agreed with the supplier.

R may be the following:

- 01 : With electromagnetic clutch.
- 02 : Monobloc, flange-mounted with electric motor.
- 03 : With hydraulic motor.
- 04 : V-belt pulley and disengaging clutch.
- 07 : On base plate with petrol or diesel engine, or with electric motor.
- 08 : Mounted on trolley with petrol or diesel engine or with electric motor.
- 09 : With bare shaft end.
- 10 : Special-tailored according to task.

Any use of the pump is to be evaluated on the basis of the materials used in the pump. In case of doubt, contact the supplier.

Pumps in material combinations A and C are primarily used for fresh water.

Pumps in material combination D are primarily used for seawater.

If the pumps are designed for special purposes the following is to be indicated:

Pump No. : \_\_\_\_\_  
Pump type : \_\_\_\_\_  
Application : \_\_\_\_\_  
Comment : \_\_\_\_\_

## 2.2 TECHNICAL DESCRIPTION

The noise level of the pump depends on the motor type supplied, as the noise from the pump can be calculated as the noise level of the motor + 2dB(A).

The capacity of the pump appears from the nameplate on the pump. If the pump has been delivered without motor, the pump capacity is to be indicated on the plate when mounting the motor.

The permissible loads on the flanges appear from the following table:

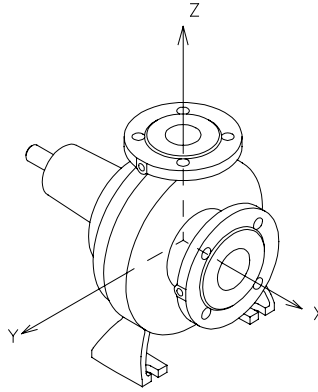

Pump	Fv N	Fh N	Σ F N	Σ Mt Nm
S-32-25-110	1250	950	1550	200
S-50-32-135	1250	950	1550	200
S-70-50-175	1350	1000	1700	200
S-70-50-220	1350	1000	1700	200
S-70-50-275	1350	1000	1700	250
S-80-70-175	1450	1050	1800	270
S-80-70-220	1450	1050	1800	270
S-80-70-275	1450	1050	1800	270
S-100-80-175	1800	1250	2200	470
S-100-80-220	1800	1250	2200	470
S-100-80-275	1800	1250	2200	470
S-125-80-220	3200	1900	3750	950
S-125-80-275	3300	2000	3850	1020
S-125-100-220	3300	2000	3850	1020

In connection with the permissible loads on the flanges the following is to be observed:

$$\frac{2}{3} F_{zout} + F_{zin} \leq F_v$$

$$\sqrt{F_{xin}^2 + F_{yin}^2} + \sqrt{F_{xout}^2 + F_{yout}^2} \leq F_h$$

$$\sqrt{M_{xin}^2 + M_{yin}^2 + M_{zin}^2} + \sqrt{M_{xout}^2 + M_{yout}^2 + M_{zout}^2} \leq M_t$$

$$\left( \frac{\Sigma F_{calc}}{\Sigma F} \right)^2 + \left( \frac{\Sigma M_{calc}}{\Sigma M_t} \right)^2 < 2$$

where index "in" is suction branch, "out" is pressure branch, and "calc" are the values calculated by the user.

### 3. INSTALLATION

#### 3.1 MOUNTING/FASTENING

The pump should be mounted and fastened on a solid base plate with a flat and horizontal surface to avoid distortion.

The max. permissible loads on the flanges stated in paragraph 2.2 are to be observed.

When mounting a V-belt pulley on the pump a bore H7 is recommended. To facilitate the mounting the hub in the V-belt pulley may be heated to about 100 °C after which the V-belt pulley is easily lead over the shaft towards the shoulder. Alternatively, the V-belt pulley may be mounted with a TAPER LOCK bush.

When dimensioning the V-belt pulley it is important to follow the rules of the DESMI nomograms for the pump size in question - contact DESMI.

If the pump is to be driven by a motor via a flexible coupling, motor and pump are to be placed on a common base plate. The following should be observed:

- Avoid distortion of the base plate.
- Avoid distortion in the piping system.
- Check that pump and motor are aligned correctly.

Below please find 2 proposals for alignment. The deviations mentioned cover a complete revolution of the coupling. The distance between the coupling halves is to be between 2 and 4 mm.

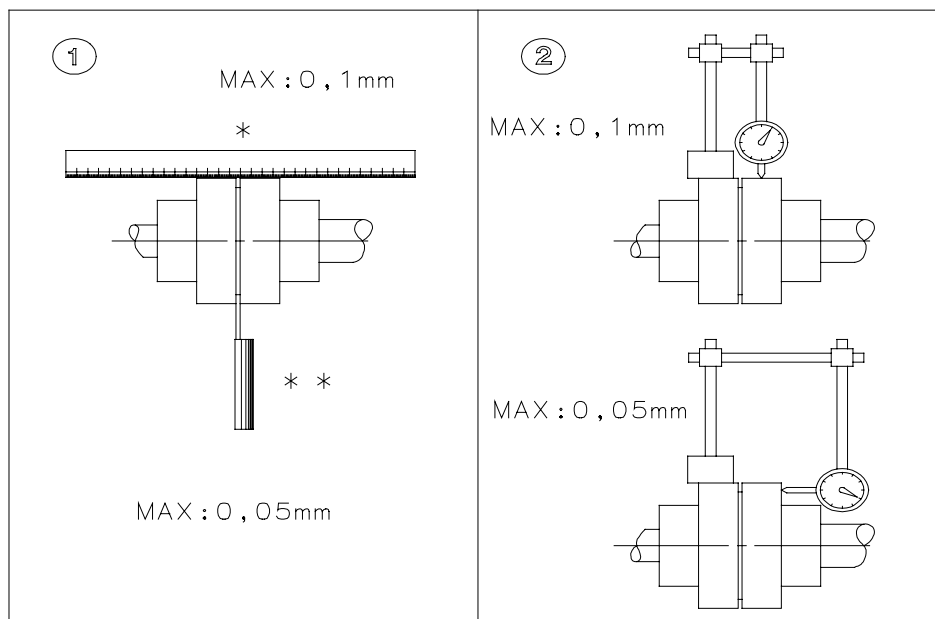

At installations pumping hot or very cold liquids, the operator must be aware that it is dangerous to touch the pump surface, and, consequently, he must take the necessary safety measures.

When connecting the pump and a prime mover the power transmission is to be equipped with a guard in accordance with the provisions of the COUNCIL DIRECTIVE of June 14, 1989, on the safety of machines.

### 3.2 WIRING



Wiring to be carried out by authorized skilled workmen according to the rules and regulations in force.

### 4. TRANSPORT/ STORAGE

The weights of the pumps (in A09 combination) are stated in the following table, and the pumps are to be lifted as shown.

Pump	Weight kg	Pump	Weight kg
S-32-25-110	21.5	S-80-70-275	86.0
S-50-32-135	22.0	S-100-80-175	72.0
S-70-50-175	42.0	S-100-80-220	92.5
S-70-50-220	58.0	S-100-80-275	107.0
S-70-50-275	72.0	S-125-80-220	116.0
S-80-70-175	53.0	S-125-80-275	122.0
S-80-70-220	59.0	S-125-100-220	138.0

The pump is to be stored in a dry area.

Before shipment the pump is to be fastened securely on pallets or the like.



The pump is to be lifted as shown here:

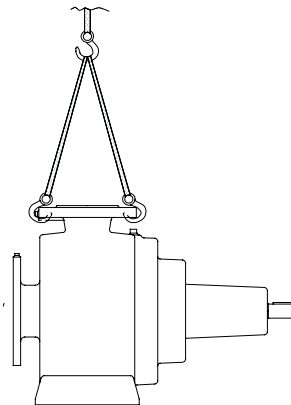

The lifting straps must not bear against sharp edges and corners.

## 5. DISMANTLING

### 5.1 ACCESS TO IMPELLER AND SHAFT SEAL

Remove Allen screws (22), which hold the shaft seal cover to the pump casing, and pull the bearing housing to remove the complete bearing housing with impeller, bearings, and shaft.

Only S-32-25-110 and S-50-32-135:

Remove Allen screw (22) which holds the bearing housing to the pump casing and pull the bearing housing with impeller and guide vane piece out of the pump casing.

Then remove Allen screw (29) (only S-32-25-110), and guide vane piece and guide ring can be dismantled from the bearing housing.

### 5.2 DISMANTLING SHAFT SEAL

Remove nut (6). Pull off the impeller. Remove Allen screws (19), which hold the bearing housing to the shaft seal cover. Pull shaft seal cover and bearing housing apart, by which shaft seal and water deflector are pulled off the shaft.

Only S-32-25-110 and S-50-32-135:

Unscrew impeller. Dismantle the oil seal ring (31) by puncturing the front to permit the oil seal ring to be pulled out with a hook. The oil seal ring cannot be used again. Dismantle the ring lock (30), and the shaft with bearings can be pulled out of the bearing housing. At the same time, the shaft seal and the water deflector are pulled off the shaft.

### 5.3 DISMANTLING SEAT

Press out the seat from behind the shaft seal cover (the bearing housing in S-32-25-110 and S-50-32-135).

### 5.4 DISMANTLING SHAFT WITH BEARINGS

Before dismantling the shaft with bearings, remove the sunk key (16). The shaft can now be pulled out of the bearing housing allowing inspection of the bearings.

### 5.5 INSPECTION

When the pump has been dismantled, check the following parts for wear and damage:

- Sealing ring/impeller: Max. clearance 0.4-0.5 mm measured in radius.  
(There is no sealing ring in S-32-25-110 and S-50-32-135)
- Shaft seal/shaft seal cover: Check the seat for flatness and cracks.  
Check the rubber parts for elasticity.
- Bearings: Replace in case of wear and noise.



## 6. ASSEMBLING

### 6.1 FITTING SEALING RING IN PUMP CASING

When fitted, the sealing ring is to bear against the shoulder of the pump casing.

### 6.2 FITTING SHAFT WITH BEARINGS

Lead shaft with bearings into the bearing housing. Fit sunk key (16). (Fit ring lock (30) and a new oil seal ring (31) in S-32-25-110 or S-50-32-135).

### 6.3 FITTING WATER DEFLECTOR

Assemble the bearing housing and the shaft seal cover. Lead the water deflector over the shaft until it touches the shaft seal cover and then further 1-1.5 mm into the shaft seal cover (the bearing housing in S-32-25-110 or S-50-32-135).

### 6.4 FITTING SHAFT SEAL

Before fitting the seat, clean the recess in the shaft seal cover (the bearing housing in S-32-25-110 or S-50-32-135). When fitting the seat, remove the protective coating without scratching the lapped surface. Dip the outer rubber ring of the seat into olive oil (or another neutral oil). Now press the seat into place with the fingers and check that all parts are correctly imbedded. If it is necessary to use tools for assembling, then protect the sliding surface of the seat to prevent it from being scratched or cut. Lubricate the inner diameter of the slide ring rubber bellows with olive oil and push it over the shaft. The use of a fitting bush as shown on the assembly drawing is recommended to avoid that the rubber bellows is cut. Push the slide ring over the shaft with the hand. If the rubber bellows is tight, use a fitting tool and take care that the slide ring is not damaged.

If the carbon ring is not fixed, it is important to check that it is fitted correctly, i.e. the chamfered/lapped side is to face the seat. The carbon ring can be held by a little grease. When using oil on the shaft, the bellows will settle and seat in about 15 minutes, and until then tightness should not be expected. After start, check by viewing the leak hole that there are no leaks.

### 6.5 FITTING IMPELLER

Fit the sunk key in the shaft and lead the impeller towards the shoulder of the shaft. Take care that the ring at the end of the shaft seal spring locates in the recess of the impeller. Secure the impeller with a washer and a nut.

Only S-32-25-110 and S-50-32-135:

Apply LOCTITE 270 or similar to the thread on the shaft. Screw the impeller towards the shoulder of the shaft. Take care that the ring at the end of the shaft seal spring locates in the recess of the impeller.

### 6.6 FITTING GUIDE RING AND GUIDE VANE PIECE (ONLY S-32-25-110)

Place the guide ring (35) in the recess of the bearing housing. Fit and fasten the guide vane piece on the guide ring. Note that the flat part of the inlet neck of the guide vane piece is to face upwards, i.e. opposite of the drain passage for the shaft seal in the bearing housing. If the shaft cannot rotate freely, dismantle the guide vane piece again, and place a shim (34) between bearing housing and guide ring.

## 6.7 FITTING BEARING HOUSING AND SHAFT SEAL COVER

Place the gasket between pump casing and shaft seal cover on the shaft seal cover where it can be held with a little grease. Lead bearing housing with shaft seal cover into place and fasten. Note that the drain hole for the shaft seal faces downwards.

S-32-25-110:

Place the gasket (21) between pump casing and bearing housing on the bearing housing. Check that the non-return flap is placed correctly in the pump casing. Lead the bearing housing into place and fasten. Note that the drain passage for the shaft seal faces downwards.

S-50-32-135:

Place the gasket (21) between pump casing and bearing housing on the bearing housing. Lead the bearing housing into place and fasten. Note that the drain passage for the shaft seal faces downwards. If the shaft cannot rotate freely, dismantle the bearing housing again, and place an extra gasket (21) between bearing housing and pump casing.

## 6.8 SHAFT

When the pump has been assembled, check that the shaft rotates freely.

## 7. FROST PROTECTION

Pumps, which are not in operation during frost periods, are to be drained to avoid frost damage. Remove the plug at the bottom to empty the pump. Alternatively, it is possible to use anti-freeze liquids in normal constructions.

## 8. DISMANTLING



Before dismantling the pump make sure that it has stopped. Empty the pump of liquid before it is dismantled from the piping system. If the pump has been pumping dangerous liquids you are to be aware of this and take the necessary safety measures. If the pump has been pumping hot liquids, take great care that it is drained before it is removed from the piping system.

## 9. START-UP



A self-priming centrifugal pump will not function until the pump casing has been filled with liquid.

The liquid also serves as coolant for the shaft seal. In order to protect the shaft seal the pump must not run dry.

WARNING
---------

For safety reasons the pump is only allowed to operate against a closed discharge valve for a short time (max. 5-10 minutes and at a max. temperature of 130°C). To protect the pump against unintentional operation it is equipped with a relief valve, which opens at a preset pressure.

Be careful: When the valve opens, the escaping liquid will be hot.

The relief valve must in **no** circumstances be removed or re-adjusted !

As regards maintenance of the relief valve - see paragraph 11.

## 9.1 STARTING

Before starting the pump check that

- the shaft rotates freely without jarring sounds.
- the pump casing is filled with liquid.

Start the pump for a moment to check the direction of rotation. If the direction is correct (i.e. in the direction of the arrow), the pump may be started.

## 10. SYSTEM BALANCING

It is often difficult to calculate a manometric delivery head in advance. It is, however, decisively important to the quantity of liquid delivered.

A considerably smaller delivery head than expected will increase the quantity of liquid delivered, causing increased power consumption and perhaps cavitation in pump and piping. In the pump the impeller may show signs of heavy erosion caused by cavitation (corrosion) which may at times render an impeller unfit for use in a very short time. Not unusually do similar erosions occur in pipe bends and valves elsewhere in the piping system.

Therefore, after start-up, it is necessary to check either the quantity of liquid delivered or the power consumption of the pump e.g. by measuring the current intensity of the connected motor. Together with a reading of the differential pressure the quantity of water delivered can be determined against the characteristics of the pump.

Should the pump not function as intended, please proceed according to the faultfinding list. Bear in mind, though, that the pump was carefully checked and tested at the factory and that the majority of faults stem from the piping system.

FAULT	CAUSE	REMEDY
The pump does not Prime	<ol style="list-style-type: none"> <li>1. The pump is not filled with liquid</li> <li>2. Leaking non-return valve in pump</li> <li>3. Wrong direction of rotation</li> <li>4. Air is drawn in because of too little liquid or leaking suction line</li> <li>5. Liquid lock in outlet line</li> <li>6. Temperature of liquid too high</li> <li>7. Air cannot escape on pressure side</li> </ol>	<p>Fill pump casing with liquid  Remove foreign body in valve/Remove any coating on mating faces  Change direction of rotation  Lower suction pipe/  Tighten suction line</p> <p>Change the pressure line so that the air can pass out freely  Replace liquid in pump casing/Wrong dimensioning/Contact DESMI  Ventilate the system</p>
The pump has no or too low capacity	<ol style="list-style-type: none"> <li>1. Wrong direction of rotation</li> <li>2. Piping system choked</li> <li>3. The pump is choked</li> <li>4. Suction line leaks Pump takes air</li> <li>5. Suction lift too high</li> <li>6. Pump and piping system wrongly dimensioned</li> </ol>	<p>Change direction of rotation to clockwise when viewed from shaft end (the direction of the arrow)  Clean or replace  Clean the pump  Find the leakage/repair the fault, non-return valve not submerged  Check data sheet Q/H curve and NPSH or contact DESMI  As 5</p>
The pump uses too much power	<ol style="list-style-type: none"> <li>1. Counter-pressure too low</li> <li>2. The liquid is heavier than water</li> <li>3. Foreign body in pump</li> <li>4. Electric motor is running on 2 phases</li> </ol>	<p>Insert orifice plate or check valve/Contact DESMI  Contact DESMI</p> <p>Dismantle the pump, remove the cause  Check fuses, cable connection, and cable</p>
The pump makes noise	<ol style="list-style-type: none"> <li>1. Cavitation in pump</li> </ol>	<p>Suction lift too high/  Suction line wrongly dimensioned/Liquid temperature too high</p>

## 11. INSPECTION AND MAINTENANCE

Inspect the shaft seal for leaks at regular intervals.

Activate the relief valve at regular intervals in order to check the function. If the valve is choked, replace or clean it, if possible.

- Before inspection of a pump without guard check that the pump cannot be started unintentionally.
- The system is to be without pressure and drained of liquid.
- The repairman must be familiar with the type of liquid, which has been pumped as well as the safety measures he is to take when handling the liquid.

### 11.1 DRAINING THE PUMP

When the piping system has been drained, note that there is still liquid in the pump. Remove the liquid by dismantling the pipe plug (75) at the bottom of the pump.

### 11.2 BEARINGS

The pump is equipped with ball bearings with a nominal life of 25,000 working hours when direct coupled to electric motor, whereas the nominal life with overhanging V-belt drive is about 10,000 working hours. The bearings are lubricated for life and require no attention but are to be replaced in case of noise or bearing wear.

## 12. REPAIRS

### 12.1 ORDERING SPARE PARTS

When ordering spare parts please always state pump type and pump No. (appears on the name plate of the pump). See also spare parts drawing with item Nos.

## 13. OPERATING DATA

The following working pressures are allowed:

<b>PUMP</b>	S-32-25-110	S-50-32-135	S-70-50-175	S-70-50-220	S-70-50-275
PRESSURE mWC	45	45	65	100	150
<b>PUMP</b>	S-80-70-175	S-80-70-220	S-80-70-275	S-100-80-175	S-100-80-220
PRESSURE mWC	65	100	160	65	100
<b>PUMP</b>	S-100-80-275	S-125-80-220	S-125-80-275	S-125-100-220	
PRESSURE mWC	150	100	150	100	

(10.2 mWC = 1 bar)

The above-mentioned max. working pressure is **NOT** valid for pumps approved by a classification society. Pumps approved by classification societies have been pressure tested according to the requirements of these societies, i.e. a test pressure of 1.5 x the permissible working pressure. The test pressure is stated in the test certificate and stamped into the discharge flange of the pump.

The powers stated in the table below are the highest possible absorbed by the pump, whereas the min./max. values for flow and pressure indicate DESMI's recommended operating range for the pump with the biggest impeller.

Pump	Max. Power kW 1450/1750/- 2950/3500 RPM	Min. Flow m <sup>3</sup> /h 1450/1750/- 2950/3500 RPM	Max. flow m <sup>3</sup> /h 1450/1750/- 2950/3500 RPM	Min. Pressure mWC 1450/1750/- 2950/3500 RPM	Max. Pressure mWC 1450/1750/- 2950/3500 RPM
S-32-25-110	0.2/0.3/0.9/1.4	2.5/3.0/4.5/5.5	6.0/7.0/12.0/13.5	1.7/2.8/8.0/12.5	3.6/5.3/15.0/21
S-50-32-135	0.3/0.5/2.1/3.5	4,0/4,5/8,0/9,0	11,0/13,5/23/27	3.0/4.2/12.0/17.0	6.0/8.7/25/35
S-70-50-175	0.8/1.2/6.0/10.0	8.0/10.0/17.5/20	20/24/45/53	5.6/8.4/19.0/27	9.2/13.5/38/53
S-70-50-220	1.6/2.7/12.3/20.5	8,0/9,0/15/20	24/27/45/55	5.5/9.5/31/40	14.2/21/63/86
S-70-50-275	3.5/6.0/22/35	10,0/12,0/14,0/16,0	26/32/32/38	16.0/21/88/123	24/34/103/143
S-80-70-175	1.1/1.8/8.3/13.5	16,0/17,5/30/35	39/48/80/95	4.6/6.0/16.5/23	8.7/12.5/36/50
S-80-70-220	2.4/4.2/18.5/31	15,5/18,5/30/35	43/53/80/95	9.5/13.0/42/59	15.5/22/64/90
S-80-70-275	4.4/7.4/32/53	15,0/18,0/30/35	40/50/80/95	16/22/67/94	25/36/103/143
S-100-80-175	1.6/2,8/12.5/21	30/35/60/70	70/85/150/170	4.6/6.2/15.0/24	8.3/12.2/34/48
S-100-80-220	3.5/6.1/27/47	28/37/58/80	85/97/170/190	7.0/9.2/31/48	14,6/21/60/82
S-100-80-275	6.8/12.0/55/92	35/40/70/80	85/100/160/180	13.5/19.5/60/90	23/33/93/130
S-125-80-220	4.5/8.0/36.5/61	60/65/100/120	135/150/240/250	5.3/10.0/30/54	12.4/19.0/55/77
S-125-80-275	8.5/15.0/70/118	50/60/100/120	120/145/220/260	14.0/19.8/62/88	24/34/94/131
S-125-100-220	5.4/9.5/46/74	70/85/140/140	170/200/300/320	6.7/10.2/34/54	12.2/17.8/51/73

#### 14. EU DECLARATION OF CONFORMITY

DESMI A/S, hereby declare that our pumps of the MODULAR S type are manufactured in conformity with the provisions of the COUNCIL DIRECTIVE of June 14, 1989, on mutual approximation of the laws of the member states on the safety of machines (89/392/EEC with subsequent amendments) with special reference to Annex I of the Directive on essential safety and health requirements in relation to the construction and manufacture of machines.

The following harmonized standards have been used:

EN 292

CE - marks are applied to pumps with prime movers only. Pumps with CE - mark and electric motor are manufactured in conformity with the low-voltage directive.

Pumps delivered by us without prime movers may only be used when the prime mover and the connection between prime mover and pump comply with the above directive as well as the low-voltage directive.

Nørresundby, December 1, 1994



Lars Billeskov Jansen  
Development Manager - Pumps

DESMI A/S  
Tagholm 1  
9400 Nørresundby

## 15. ASSEMBLY DRAWINGS

Assembly drawings of S-32-25-110 and S-50-32-135 are shown on the next pages.

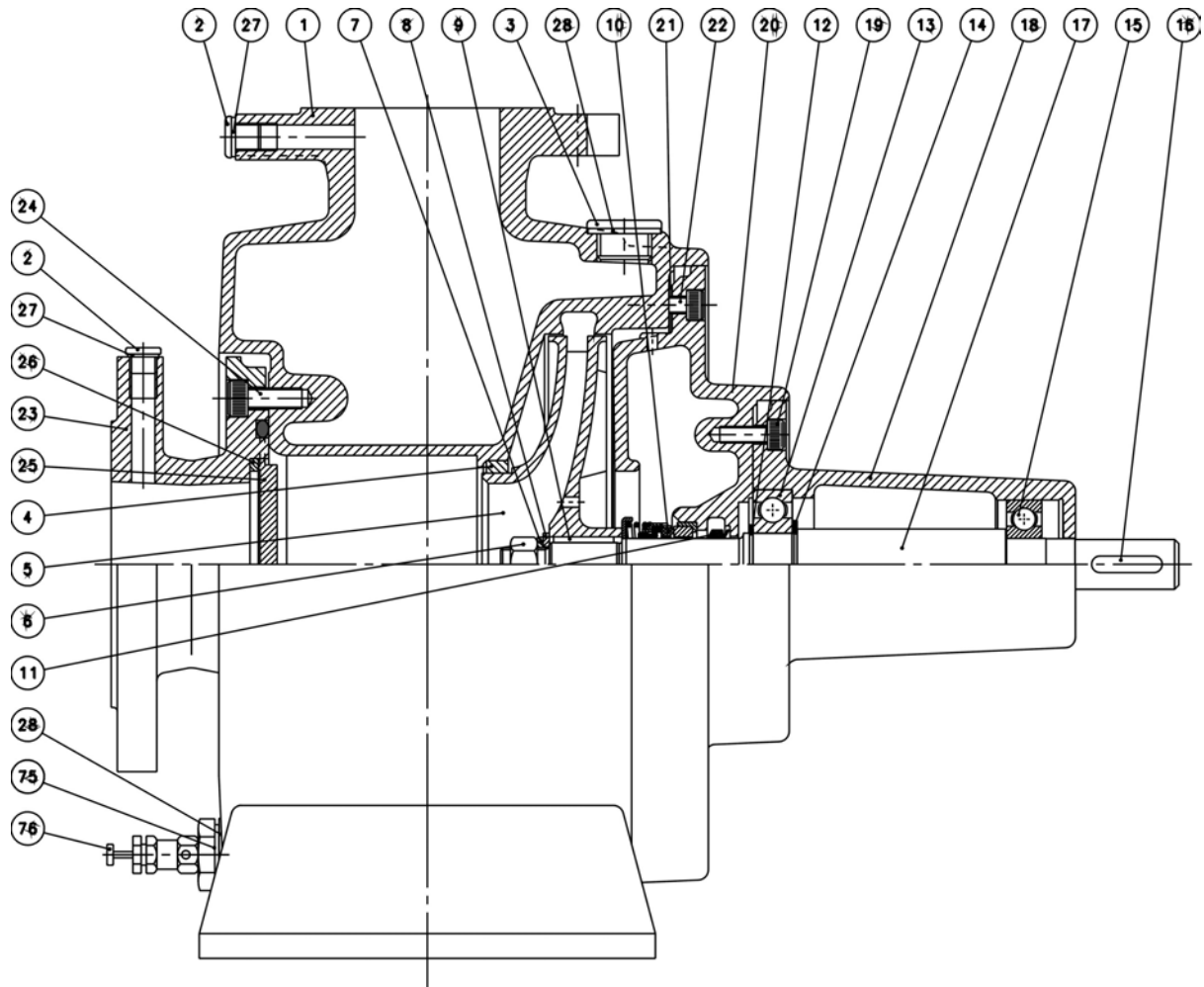

## 16. SPARE PARTS LISTS

Spare parts lists for S-32-25-110 and S-50-32-135 are shown on the next pages.

1 Pump casing	11 Water deflector	21 Gasket
2 Pipe plug	12 Ring lock	22 Allen screw
3 Pipe plug	13 Ball bearing	23 Suction piece
4 Sealing ring	14 Support disc	24 Allen screw
5 Impeller	15 Ball bearing	25 Non-return flap
6 Nut	16 Sunk key	26 Contact ring
7 Spring collar	17 Shaft	27 Gasket
8 Washer	18 Bearing housing	28 Gasket
9 Sunk key	19 Allen screw	75 Drain plug
10 Mechanical shaft seal	20 Shaft seal cover	76 Relief valve



## ASSEMBLY DRAWING S-32-25-110

Assembly drawing of S-50-32-135 is shown on the next page.

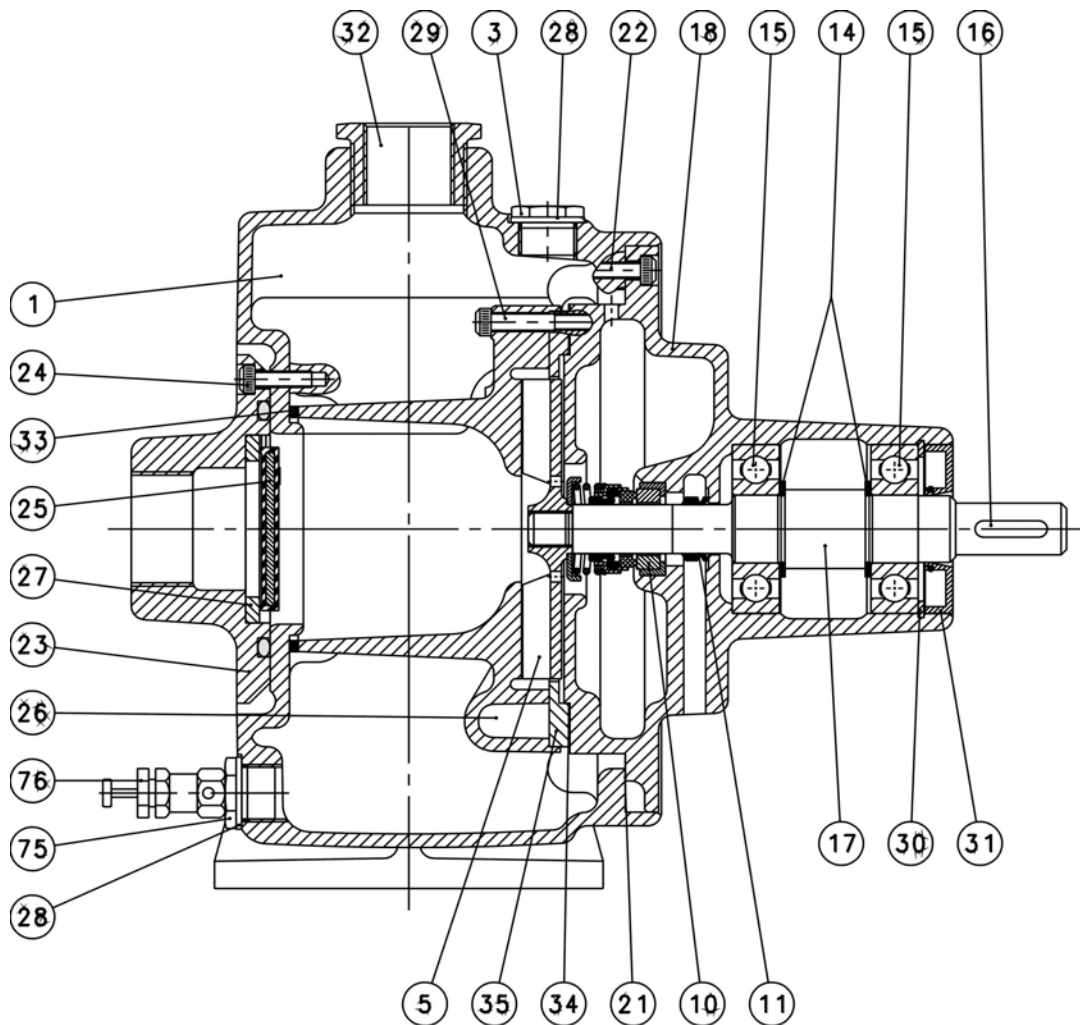

## SPARE PARTS LIST S-32-25-110

Spare parts list for S-50-32-135 is shown on the next page.

1 Pump casing	18 Bearing housing	29 Allen screw
3 Pipe plug	21 Gasket	30 Ring lock
5 Impeller	22 Allen screw	31 Oil seal ring
10 Mech. shaft seal	23 Suction piece	32 Reducing bush
11 Water deflector	24 Allen screw	33 Gasket
14 Support disc	25 Non-return flap	34 Shim
15 Ball bearing	26 Guide vane piece	35 Guide ring
16 Sunk key	27 Contact ring	75 Drain plug
17 Shaft	28 Sealing washer	76 Relief valve

**ASSEMBLY DRAWING S-50-32-135**

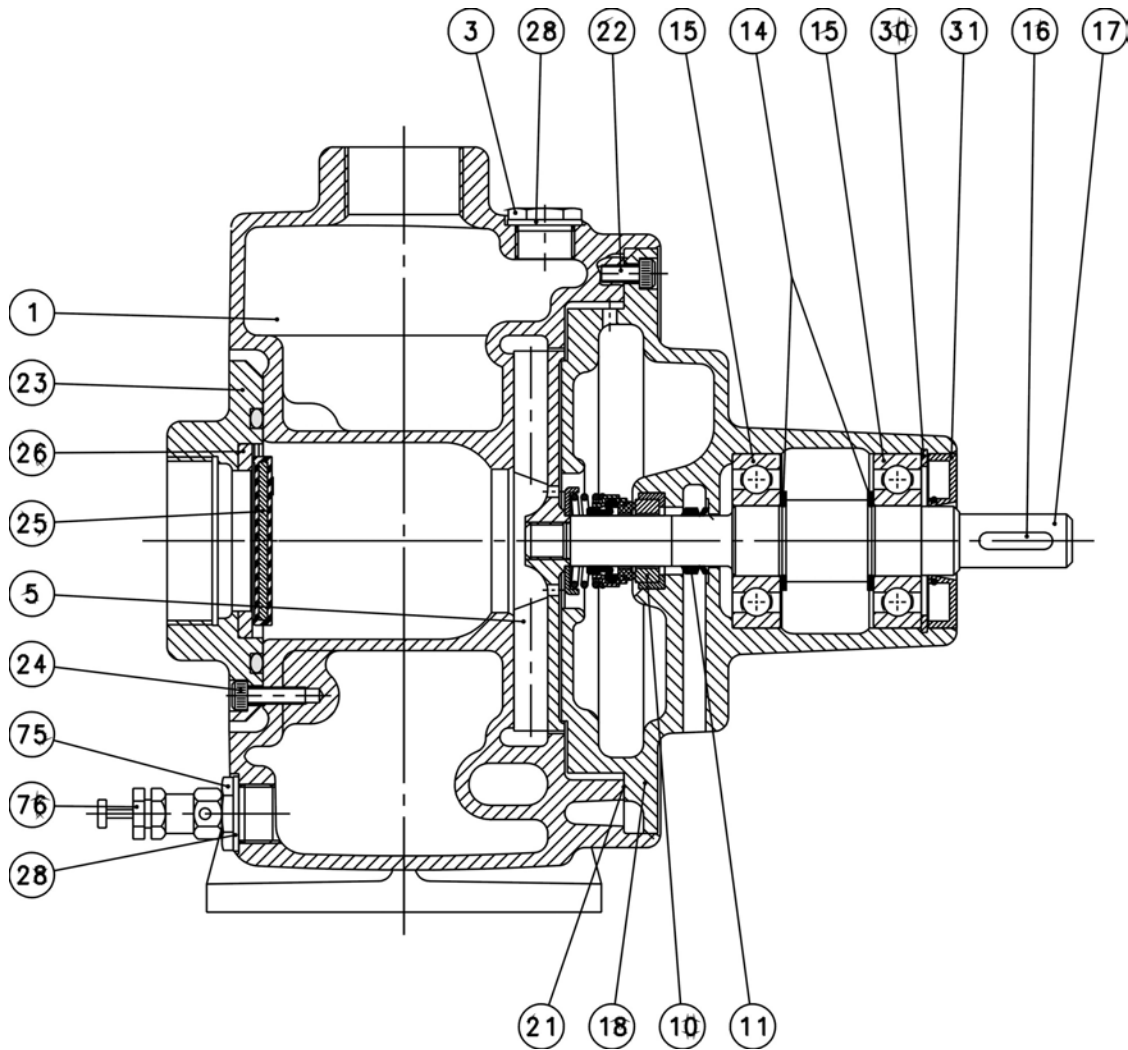

**SPARE PARTS LIST S-50-32-135**

1 Pump casing	16 Sunk key	25 Non-return flap
3 Pipe plug	17 Shaft	26 Contact ring
5 Impeller	18 Bearing housing	28 Sealing washer
10 Mech. shaft seal	21 Gasket	30 Ring lock
11 Water deflector	22 Allen screw	31 Oil seal ring
14 Support disc	23 Suction piece	75 Drain plug
15 Ball bearing	24 Allen screw	76 Relief valve

### 17. DIMENSIONAL SKETCH

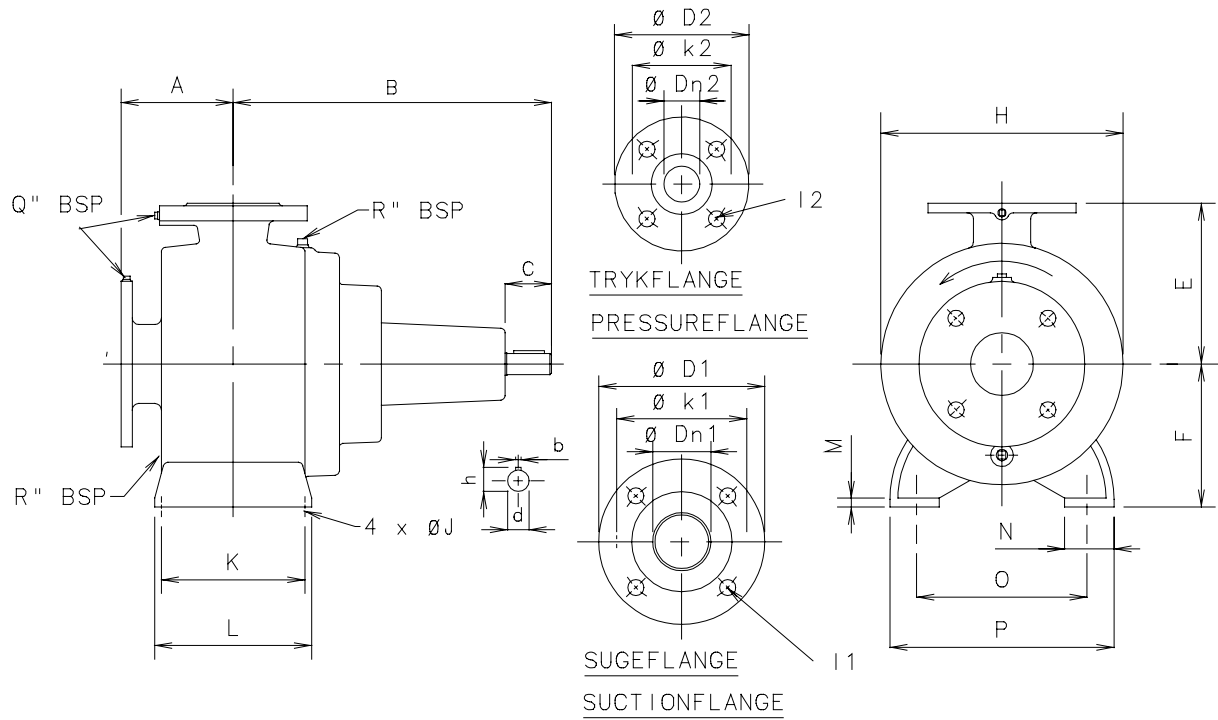

See also table on the next page

Type	A	B	C	H	E	F	d	h	b	J	K	L	M	N
S-32-25-110	100	237	40	234	155	132	19j6	21,5	6	12	110	140	10	56
S-50-32-135	84	237	40	234	140	132	19j6	21,5	6	12	110	140	10	56
S-70-50-175	125	355	50	270	180	160	24j6	27	8	15	145	175	10	55
S-70-50-220	134,5	352	50	330	220	190	24j6	27	8	15	170	200	12	68
S-70-50-275	140	350	50	390	240	225	24j6	27	8	19	170	210	12	75
S-80-70-175	150,5	363	50	295	200	180	24j6	27	8	15	190	220	13	69
S-80-70-220	155	365	50	330	220	190	24j6	27	8	15	190	220	12	70
S-80-70-275	150	360	50	390	250	225	24j6	27	8	19	170	210	12	75
S-100-80-175	175,5	374	50	344	240	200	24j6	27	8	15	220	270	13	72
S-100-80-220	180	376	50	400	280	250	24j6	27	8	19	225	265	15	90
S-100-80-275	180	465	80	425	280	250	32j6	35	10	19	225	265	14	90
S-125-80-220	204	480	80	424	280	250	32j6	35	10	19	260	300	16	95
S-125-80-275	202	480	80	454	300	260	32j6	35	10	19	260	300	14	90
S-125-100-220	235	500	80	476	315	280	32j6	35	10	19	330	370	16	105

Type	O	P	D1	K1	Dn1	l1	D2	k2	Dn2	L2	Q	R
S-32-25-110	160	230	—	—	1¼" BSP	—	—	...	1" BSP	—	...	1/2" BSP
S-50-32-135	160	230	—	—	2" BSP	—	—	-	1¼" BSP	...	-	1/2" BSP
S-70-50-175	190	250	185	145	70	4x18	165	125	50	4x18	1/4" BSP	1/2" BSP
S-70-50-220	230	300	185	145	70	4x18	165	125	50	4x18	1/4" BSP	1/2" BSP
S-70-50-275	280	360	185	145	70	4x18	165	125	50	4x18	1/4" BSP	1/2" BSP
S-80-70-175	200	273	200	160	80	8x18	185	145	70	4x18	1/4" BSP	3/4" BSP
S-80-70-220	230	305	200	160	80	8x18	185	145	70	4x18	1/4" BSP	3/4" BSP
S-80-70-275	280	360	200	160	80	8x18	185	145	70	4x18	1/4" BSP	3/4" BSP
S-100-80-175	230	319	220	180	100	8x18	200	160	80	8x18	1/4" BSP	3/4" BSP
S-100-80-220	265	365	220	180	100	8x18	200	160	80	8x18	1/4" BSP	3/4" BSP
S-100-80-275	280	380	220	180	100	8x18	200	160	80	8x18	1/4" BSP	3/4" BSP
S-125-80-220	280	382	250	210	125	8x18	200	160	80	8x18	1/4" BSP	3/4" BSP
S-125-80-275	320	414	250	210	125	8x18	200	160	80	8x18	1/4" BSP	3/4" BSP
S-125-100-220	320	445	250	210	125	8x18	220	180	100	8x18	1/4" BSP	3/4" BSP