

V4

GORMAN-RUPP PMB

Pump Motor Base

General Description



The Gorman Rupp PMB V4 is an electrical driven self priming centrifugal pump set for pumping clean water, dirty water and/or sewage. The pump sets are available in 3 configurations.

DIRECT COUPLED

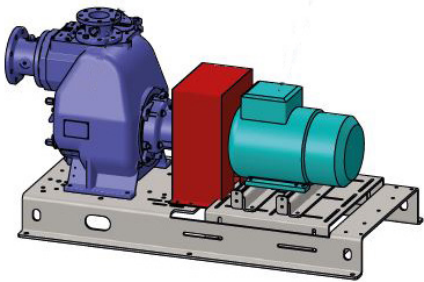

In this version, the motor is connected to the pump by means of a flexible coupling.

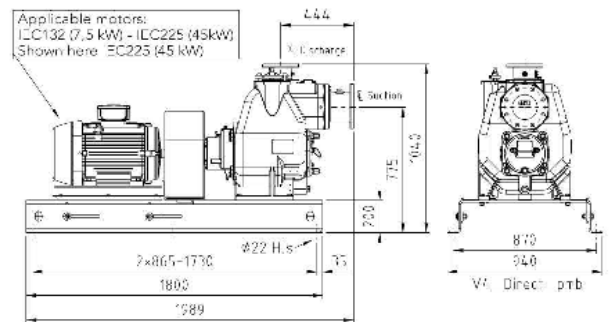

HORIZONTAL BELT DRIVE

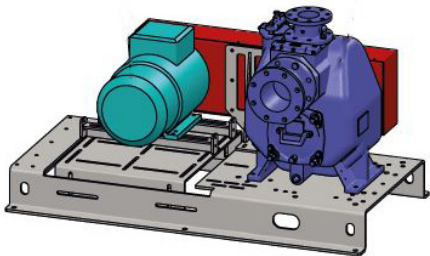

In this version, the motor is connected to the pump by means of a V-belt transmission. By varying the gear ratio, the exact pump speed can be set. The motor can be optionally placed on the left or right hand side of the pump.

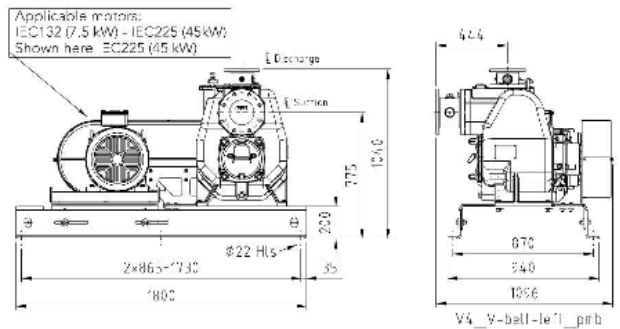

VERTICAL BELT DRIVE

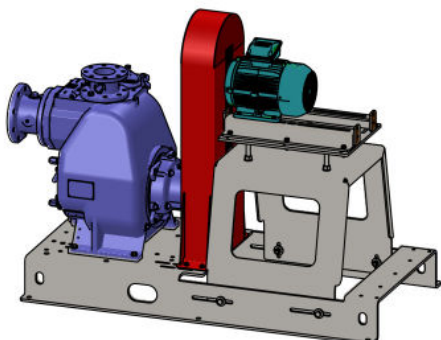

In this version, the motor is connected to the pump by means of a V belt transmission. By varying the gear ratio, the exact pump speed can be set.

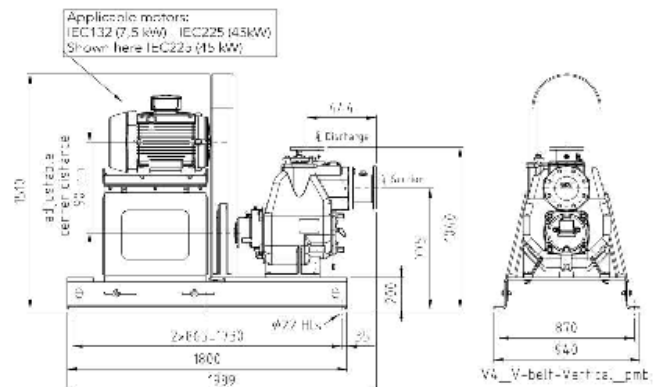

V4

GORMAN-RUPP PMB

Pump Motor Base

General Description



PUMP SPECIFICATIONS

The GormanRupp Super V4 hydraulic end for the PMB pumps sets are available in a variety of versions. Table 1 gives you an overview of the various styles of pumps:

Model	Max. Capacity	Max. Head	Max. Solids handling
V4A	260	50	3" / 76,2 mm
V4C	220	47	3" / 76,2 mm

Table 1

A-version

Basic version of the Ultra V.

C-version

Basically an A version Ultra V, fitted with the Eradicator wear plate to prevent clogging from fibrous contents.

PUMP MATERIAL SPECIFICATIONS

Gorman-Rupp pumps all bear a numeric indication of the material code. This code indicates the main materials used in the pump.

Material code	Pump Casing	Impeller	Wear Plate	Wearplate Hardware	Pump Shaft	Seal Plate
3	CI	DI	CI	STEEL	STEEL	CI
60	CI	DI	CI	STEEL	STEEL	CI
61	CI	AISI316	AISI316	AISI316	AISI316	CI
65	CD4MCU	CD4MCU	CD4MCU	AISI316	AISI316	CD4MCU
71	CI	ADI	HS	STEEL	STEEL	ADI
75	ADI	ADI of HiCro-65	ADI	STEEL	STEEL	ADI

Table 2

ADI: Austempered Ductile Iron, 400 Brinell

CD4MCU: Duplex Stainless Steel, 325 Brinell*

CI: Cast Iron GG30

ADI: Ductile Iron

HiCro 650: High Chrome alloy 650 Brinell*

HS: Hardened Alloy Steel

SIC/SIC: Silicone Carbide Seal Faces

SST17-4: Hardened Stainless Steel

SST316: Austenitic Stainless Steel grade 316, 150 Brinell

TC/TC: Tungsten Titanium Carbide Seal Faces

* Hardness values (Brinell) are indicative

PMB FRAME DESIGN

Frame	Steel frame, galvanized
Cover plate	Aluminium, powder coated red
Hardware	Electrogalvanized

TRANSMISSION SYSTEM

Direct coupled	Flexibel belt coupling
Belt drive	Reinforced V-belts
Safety factor	1.2 - 1.5

MOTOR SPECIFICATIONS

3-phase, multi-Voltage, IP55; Premium efficiency IE3, IEC induction motor.

Mouting: B3

Voltage: 220-240/380-415V / 380- 415/660V

Class: "F" isolation ($\Delta T=80K$)

Continuous insulation S1; Design N

Cast iron frame. Suitable for use with an AC drive.

IE4 and IE5 motors and other motor upgrades available on request.